



CALL US FIRST!

DO NOT RETURN ITEM TO STORE

Service Policy: We will replace any parts which are defective, missing or damaged during assembly. Please contact Whittier Wood Products customer service department directly (by phone, fax, mail or email) for replacement parts.

Hours: Our friendly customer service staff can be reached Monday-Friday 7:00 a.m. to 5:00 p.m. (Pacific Time). A message can be left 24 hours a day, 7 days a week.

To Order: Provide the complete furniture model number, part letter, production code, quantity needed, reason for replacement and your full name and address along with a telephone number in case we need to contact you.

Parts ship from our Eugene, Oregon factory within 1 or 2 business days from the time we receive the request. Please allow 5-10 business days for delivery.

800-653-3336

Outside U.S. or Canada: 541-687-0213

Fax: 541-687-2060 • Email: info@whittierwood.com
Mail: P.O. Box 2827 • Eugene, Oregon 97402, U.S.A.

173W
24" Café
Counterstool

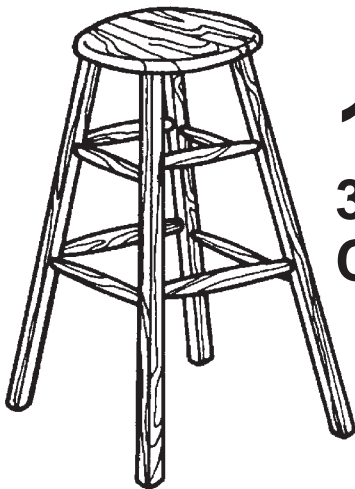
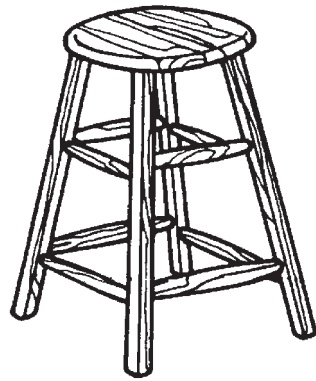

176W
30"
Café Barstool

Congratulations!

*This fine piece of furniture will make a handsome addition to your home. For the best results, start by reading both the Assembly Instructions and Finishing Hints **before** you begin your project.*

For normal household use only.
NOT recommended for commercial use.



Do not climb or stand on this piece of furniture.

DESIGN SUBJECT TO CHANGE WITHOUT NOTICE.

IMPORTANT NOTES:

- Read both the Assembly Instructions and Finishing Hints completely before beginning.
- Store the parts: 1) in their box; 2) in a dry place; 3) in temperatures ranging from 40° to 90°. (Not on a cold, possibly damp, cement floor.)
- Inspect your furniture periodically for any loose glue joints or screws, or any other problem which may be affecting the stability of your furniture. Tighten or repair as needed.



P.O. Box 2827
Eugene, OR 97402 USA

Production Code:

173W & 176W Café Stools

TOOLS REQUIRED:

Hammer, rubber mallet, slow-drying two-part epoxy glue.

BEFORE BEGINNING ASSEMBLY, check that the quantities of the parts received match those on parts list below.

| PART | DESCRIPTION | QTY. | PART | DESCRIPTION | QTY. |
|------|---------------------------|------|------|--|------|
| AA | Left Leg | 2 | E | Seat | 1 |
| BB | Right Leg | 2 | F | #8 x 1 ⁵ / ₈ " Black Screw | 4 |
| CC | Short Stretcher | 4 | G | #8 x 1 ¹ / ₄ " Black Screw | 8 |
| D | Long Stretcher | 4 | | | |

ASSEMBLY INSTRUCTIONS

IMPORTANT!

USE A SLOW-DRYING EPOXY GLUE. ONCE YOU START GLUING THE STOOL TOGETHER, CONTINUE UNTIL COMPLETE.

Before beginning assembly, lay out all the parts to become familiar with their location on the stool. Note that there are two Left Legs and two Right Legs. When a leg is laying on its side with the two upper holes facing up, the Left Leg will have the other two holes facing left and the Right Leg will have the other two holes facing right. (See FIGURE 1.)

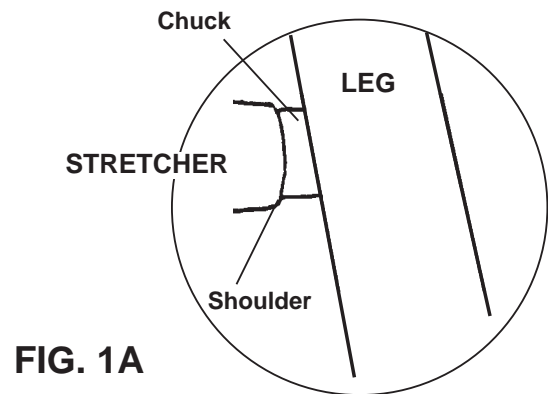
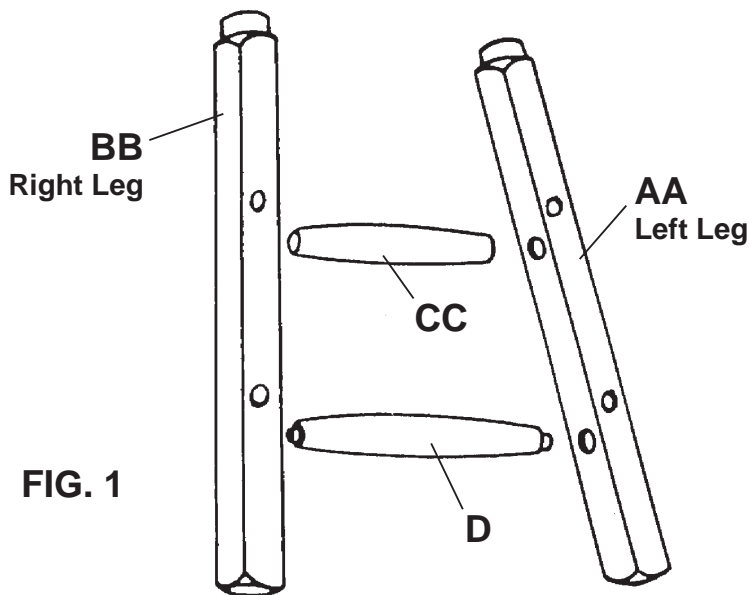

TO ASSEMBLE LEGS AND STRETCHERS:

NOTE: To make attachment of leg assembly to Seat easier, **DO NOT** insert Stretchers all the way into the Legs. The shoulder should not be snug against the Leg. Allow approximately 1/4 inch of the chuck to show. See FIGURE 1A.

- 1) Lay a Left Leg (AA) and a Right Leg (BB) so that the lower holes are facing each other. Apply an even coat of glue to the holes that are facing each other. Insert a Short Stretcher (CC) into the upper holes and a Long Stretcher (D) into the lower holes. See FIGURE 1.
- 2) Repeat step 1 with the other pair of legs.

FIG. 2

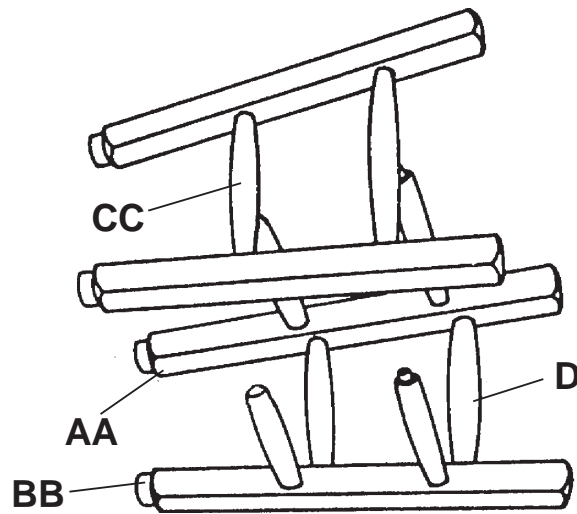

- 3) Apply an even coat of glue to the remaining four holes in each pair of legs. With one pair of legs laying on its side, insert the Short Stretchers into the upper holes and the Long Stretchers into the lower holes. Now take the other pair of legs and tap the stretchers into the proper holes (see FIGURE 2). You have now completed the undercarriage assembly. **Proceed to Step 4 without delay.**

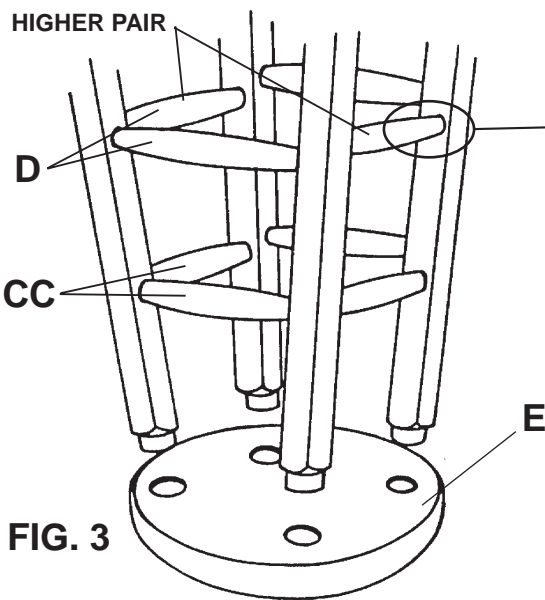

FIG. 3

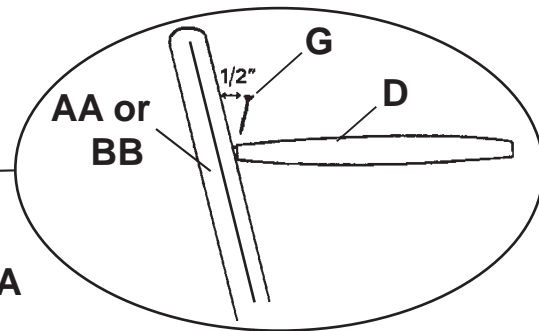

FIG. 4A

To insert screw at proper angle, the screw head should be approximately 1/2" from the nearest surface when starting the screw. Insert the screws into the slightly higher pair of Long Stretchers first.

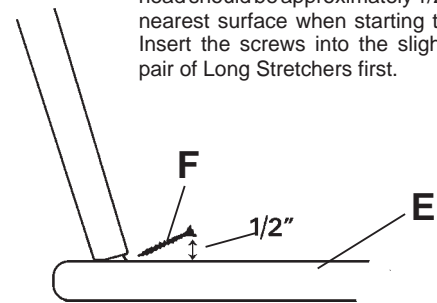

FIG. 4

TO ATTACH LEG ASSEMBLY TO SEAT

- 4) Apply an even coat of glue inside the four leg holes in the Seat (E). Insert the four legs into the holes in the Seat and tap them firmly into place. Tap Stretchers completely into the Legs after leg assembly is attached to seat. After all legs are in place, set the stool on a hard flat surface to make sure that the legs are even, and the stool does not wobble. If the stool does wobble, determine which two legs seem to be short (they will be diagonally across from each other). Turn the stool over and pull these legs toward each other. Check to see if the wobble has been corrected. Repeat this step until stool sits level. Allow the glue to set 4 to 6 hours.
- 5) For added strength, screw a #8 x 1⁵/₈" Black Screw (F) through each leg chuck into the seat. The screws must be inserted at such an angle so that they do not go through the other side of the leg or top of the seat. Screw a #8 x 1¹/₄" Black Screw (G) through both ends of the four Long Stretchers (D) into the legs. Insert the screws into the slightly higher pair of Long Stretchers first. The screws must be inserted at such an angle so that they do not go through the other side of the leg. See FIGURE 4A. No Screws are required for the Short Stretchers (CC).

