

ASSEMBLY INSTRUCTIONS

669W Espresso Barstool (2 pack)

Note: Quantities shown below are for each stool.

| PARTS | | |
|-------|--------------------|-----|
| ITEM | DESCRIPTION | QTY |
| 1 | Chair Back | 1 |
| 2 | Front Leg Assembly | 1 |
| 3 | "U" Frame (large) | 1 |
| 4 | "U" Frame (small) | 1 |
| 5 | Wooden Seat | 1 |

Thank you for purchasing this quality product.

Be sure to check all packing material carefully for small parts which may have come loose inside the carton during shipment.

Count all parts and hardware and compare them to the list to the left to make sure all parts are present.

For information or replacement parts, please contact
Whittier Wood Furniture at 800-653-3336

Outside the US or Canada: 541-687-0213

P.O. Box 2827 • Eugene, Oregon - USA 97402

We will replace any parts that are defective, missing, or damaged during assembly. Business hours: Mon.-Fri. 7:00 to 5:00 Pacific time.

You may leave a message 24 hours, seven days a week.

TOOLS REQUIRED: Phillips Screwdriver, Wood Glue, Mallet or Padded Hammer

STEP 1

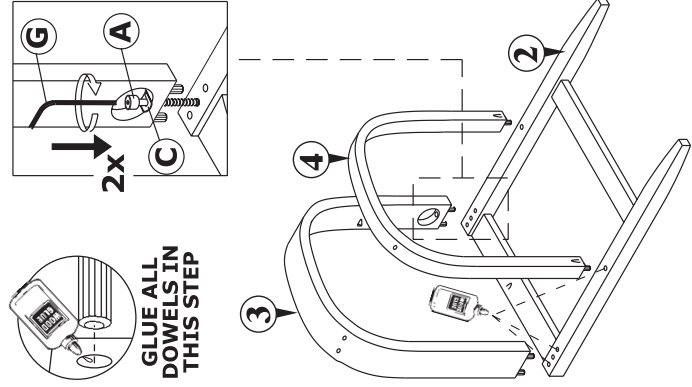

STEP 2

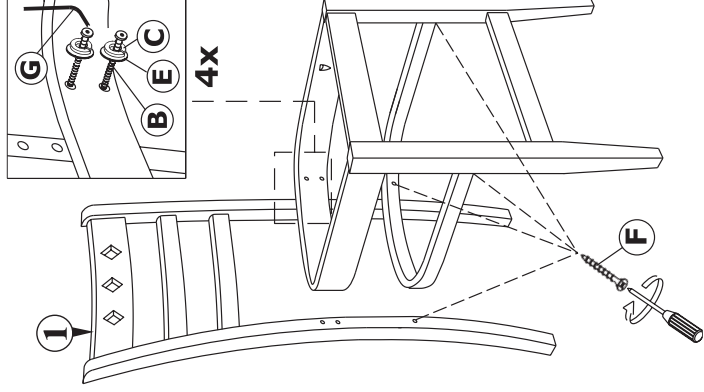

STEP 3

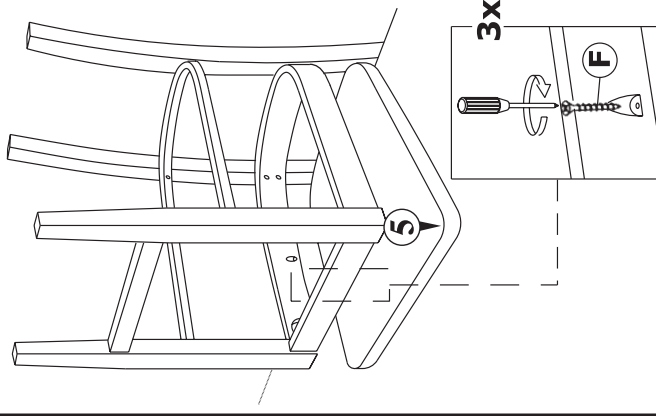

COMPLETED STOOL

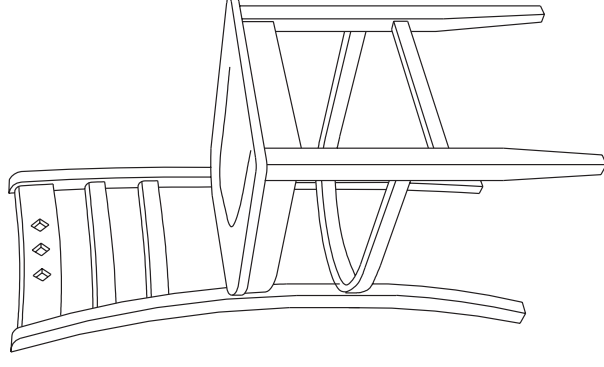

This wood product has not been coated with any type of clear sealer or finish.

CHOOSING THE FINISH:

1. Choose a finish that will meet your expectations for the product you are finishing. Are you matching existing furniture or do you want a “natural” finish? Is the piece to be functional, decorative or both? The answers to these questions may affect the type of finish you choose.
2. Use products of the same brand to ensure compatibility of products.
3. **ALWAYS** follow the stain manufacturer’s instructions. Parawood is a porous hardwood and often looks best when following the finishing directions for softwoods.
4. We recommend using a wood conditioner under oil base stains.
5. Work in a well-ventilated and well-lit area.

GETTING STARTED:

BASIC EQUIPMENT:

- Rubber gloves
- Rags
- Paper towels
- Q-tips
- Tack cloth
- Drop cloth
- Paint brushes (bristle and foam)
- #220 & #320 sandpaper
- Mineral spirits

1. **Assembly Instructions may contain special finishing information for that item.** Completely read both the Assembly Instructions and Finishing Hints before beginning your project.
2. Sand the entire piece using #220 grit sandpaper. Sand with the grain of the wood on flat surfaces and opposite the grain on turnings. End grain (table top ends, seat edges, grooves on turnings, etc.) accepts more stain. Extra sanding in these areas with #320 grit sandpaper will reduce stain absorption and create a more evenly stained piece.
3. When sanding is completed, wipe the surface of your furniture with a cloth or tack rag. Make sure the item is free of dust before proceeding.
4. Due to the assembly procedures for chairs, rockers and stools, we recommend finishing the unit **AFTER** you assemble the product.
5. If you choose to finish your chairs, rockers or stools prior to assembly, it is **imperative** that you keep the finishing product off of the ends of dowels, spindles and the mortise holes where the wood is joined. To do that, place masking tape around the ends, being careful to cover only the section that will be inserted. (Remove the tape after the finish has dried and before the furniture is assembled.) Wood glue **will not bond** if finishing products are present. If you do get finishing product in these areas, it must be removed to ensure proper bonding.
6. If glue is used in the assembly of your furniture, remove any excess glue spots or drips before finishing. Wood surfaces with glue **WILL NOT** accept stains and will leave a light spot. To remove glue, wipe off as much as possible while it is wet and then lightly sand the surface until the remaining glue is removed.

STAINING:

1. Read and follow label directions. Stir stain well before starting.
2. Test stain on an inconspicuous spot on your project.
3. Apply stain with a poly brush or lint-free cloth. Apply stain over a small area and wipe off excess.
4. Work in small areas to control the color more easily.
5. Q-tips are ideal for hard-to-get areas.
6. Allow the stain to dry **thoroughly** before proceeding.

APPLYING THE TOP COAT:

1. **All surfaces** (including the underside of table tops and the insides of drawers) **must be sealed with a top coat.** This will help minimize wood swelling and shrinkage due to changes in moisture content or temperature.
2. **Always read and follow all label directions.** Stir your finish coat gently. **Do not shake the can.** If you do, it will create bubbles that are difficult to remove.
3. We recommend that you **apply a minimum of two coats when using polyurethane or varnish.** Sand lightly between coats using #320 grit sandpaper or 00 steel wool for the smoothest possible finish.
4. Some water-based finishes tend to slightly raise the grain. You can easily control that by sanding. However, do not use steel wool when you use water-based finishes. Strands of steel fiber caught in the wood can cause rust spots when coated with any water-based product.
5. No top coat is required for paint.

PAINTING:

1. For best results when painting, first coat the wood with a primer. An oil-based primer is best for a smooth finish. If you do not wish to use a solvent-based primer, a water-based primer works almost as well.
2. Buy a quality brand paint. You may use a satin, semi-gloss or gloss sheen. Apply a second coat for a smooth finish. Lightly sand between coats using #320 grit sandpaper so the second coat will bond well. Repeat as desired.
3. Since there is such a wide variation between paint manufacturers, refer to your paint supplier for specific advice on using the paint you purchase.