

Contemporary Extension Table

(40 x 60-78)

Thank you for purchasing this quality product.





Be sure to check all packing material carefully for small parts which may have come loose inside the carton during shipment.

Count all parts and hardware, compare with the parts list below to be sure all parts are present.

For information or replacement parts, please contact **Whittier Wood Products customer service directly by calling toll free at 800-653-3336**

or writing to P.O. Box 2827 • Eugene, Oregon - USA 97402
We will replace any parts which are defective, missing, or damaged during assembly.

Business hours: Mon.-Fri. 7:00 to 5:00 Pacific time.
A message can be left 24 hours, 7 days a week.

PARTS		
ITEM	DESCRIPTION	QTY
1	Table Top with Apron	1
2	Table Leg	4
HARDWARE		
ITEM	DESCRIPTION	QTY
A	Wrench 	1
B	5/16" x 2 1/2" Hex Bolt 	8
C	5/16" Flat Washer 	8
D	Spring Washer 	8

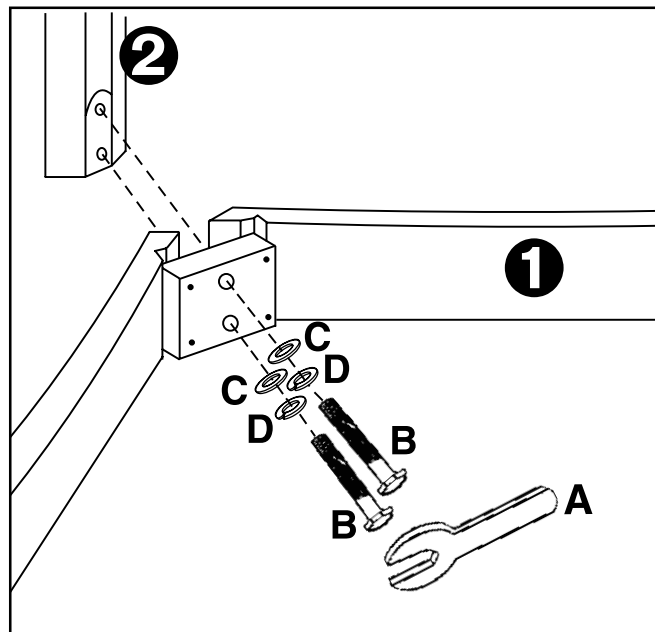
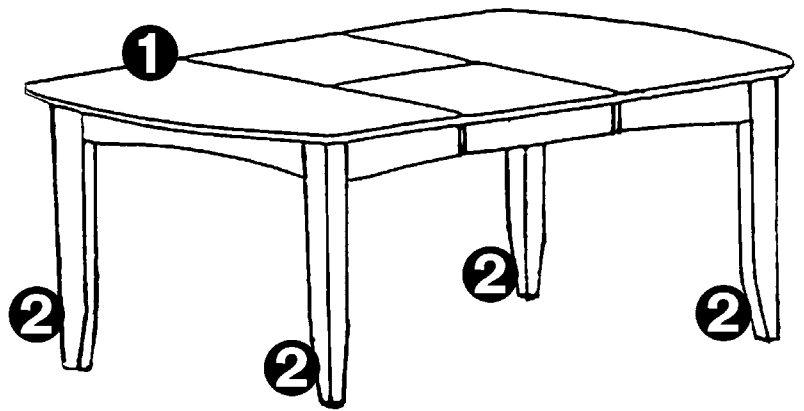

1. Lay the table face down on a clean and flat, soft surface and use caution during assembly to prevent scratching the table top.
2. Place a leg in corner of table and insert two bolts with washers through the holes in corner block of apron frame into the leg and tighten with wrench. Repeat for the other legs.

FINISHING HINTS

This wood product has not been coated with any type of clear sealer or finish.

CHOOSING THE FINISH:

1. Choose a finish that will meet your expectations for the product you are finishing. Are you matching existing furniture or do you want a "natural" finish? Is the piece to be functional, decorative or both? The answers to these questions may affect the type of finish you choose.
2. Use products of the same brand to ensure compatibility of products.
3. **ALWAYS** follow the stain manufacturer's instructions. Parawood is a porous hardwood and often looks best when following the finishing directions for softwoods.
4. We recommend using a wood conditioner under oil base stains.
5. Work in a well ventilated and well lit area.

GETTING STARTED:

BASIC EQUIPMENT:

- Rubber gloves
- Rags
- Paper towels
- Q-tips
- Tack cloth
- Drop cloth
- Paint brushes (bristle and foam)
- #220 & #320 sandpaper
- Mineral spirits

1. **Assembly Instructions may contain special finishing information for that item.** Read both the Assembly Instructions and these Finishing Hints completely before beginning.
2. Sand the entire piece, using #220 grit sandpaper. Sand with the grain of the wood on flat surfaces and opposite the grain on turnings. End grain (table top ends, seat edges, grooves on turnings, etc.) accepts more stain. Extra sanding in these areas with a #320 grit sandpaper will reduce stain absorption, creating a more evenly stained piece.
3. When sanding is completed, wipe the surface of your furniture with a cloth or tack rag. Make sure the item is free of dust before proceeding.
4. For most products, we recommend preparing and staining the wood prior to assembly. Due to the assembly procedures for chairs, rockers and stools, we recommend assembling these items prior to finishing.
5. If you do choose to finish chairs, rockers or stools prior to assembly, it is **imperative** that you protect the ends of dowels and spindles, and the mortise holes where the wood is joined, from finishing products. Use masking tape around the ends, being careful to cover only the section that will be inserted (remove the tape after the finish has dried and before the furniture is assembled). Wood glue **will not bond** if finishing products are present. If you do get finishing product in these areas, it must be removed to ensure proper bonding.
6. If glue is used in assembly of your furniture, remove any excess glue spots or drips before finishing. Wood surfaces with glue **WILL NOT** accept stains, and will leave a light spot. To remove glue, wipe off as much as possible while wet, then lightly sand the surface until the remaining glue is removed.

STAINING:

1. Read and follow label directions. Stir stain well before starting.
2. Test stain on an inconspicuous spot on your project.
3. Apply stain with a poly brush or lint-free cloth. Apply stain over a small area and wipe off excess.
4. Working in small areas will make the color easier to control.
5. Allow to dry **thoroughly** before proceeding.

APPLYING THE TOP COAT:

1. **All surfaces** (including the underside of table tops and inside drawers) **must be sealed with a top coat.** This will help minimize wood swelling and shrinkage due to changes in moisture content or temperature.
2. **Always read and follow all label directions.** Stir your finish coat gently, **do not shake.** It will create bubbles that are hard to remove.
3. We recommend that you **apply a minimum of two coats when using polyurethane or varnish.** Sand lightly between coats using a #320 grit sandpaper or 00 steel wool for the smoothest possible finish.
4. Some water-based finishes tend to raise the grain slightly. This can be easily controlled with this sanding step. However, do not use steel wool when using water-based finishes. Strands of steel fiber caught in the wood can cause rust spots when coated with any water-based product.
5. No top coat is required for paint.

PAINTING:

1. For best results when painting, first coat the wood with a primer. An oil based primer would be best for a smooth finish. If you do not wish to use a solvent based primer, a water based primer would work almost as well.
2. Buy a quality brand paint. You may use a satin, semi-gloss, or gloss sheen. Apply a second coat for a smooth finish. Lightly sand between coats using a #320 grit sandpaper, so that the second coat will bond well. Repeat as desired.
3. Since there is such a variation between paint manufacturers, refer to your paint supplier for specific advice on using the paint that you purchase.