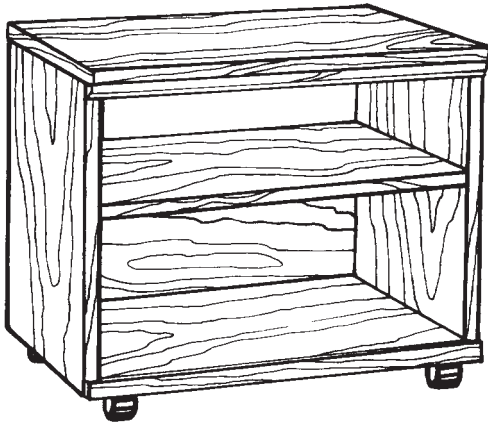


Model #

# 712Wb

## TV/VCR Unit


Assembly Instructions



### Congratulations!

This fine piece of furniture will make a handsome addition to your home. For the best results, start by reading both the Assembly Instructions and Finishing Hints **before** you begin your project.

**For normal household use only.  
NOT recommended for commercial use.**

 Do not climb, sit or stand on this piece of furniture.

Unload items from this unit prior to moving.

Do not overload shelves on this unit.

Before loading or moving this unit, check all screws and supports for tightness.

**DESIGN SUBJECT TO CHANGE WITHOUT NOTICE.**



P.O. Box 2827  
Eugene, OR 97402 USA



**CALL US FIRST!**  
**DO NOT RETURN ITEM TO STORE**

**Service Policy:** We will replace any parts which are defective, missing or damaged during assembly. Please contact Whittier Wood Products customer service department directly (by phone, fax, mail or email) for replacement parts.

**Hours:** Our friendly customer service staff can be reached Monday-Friday 7:00 a.m. to 5:00 p.m. (Pacific Time). A message can be left 24 hours a day, 7 days a week.

**To Order:** Provide the complete furniture model number (upper left corner of this page), part letter, production code, quantity needed, reason for replacement and your full name and address along with a telephone number in case we need to contact you.

*Parts ship from our Eugene, Oregon factory within 1 or 2 business days from the time we receive the request. Please allow 5-10 business days for delivery.*

**800-653-3336**

Outside U.S. or Canada: 541-687-0213

Fax: 541-687-2060 • [www.whittierwood.com](http://www.whittierwood.com)

Mail: P.O. Box 2827 • Eugene, Oregon 97402, U.S.A.

### IMPORTANT NOTES:

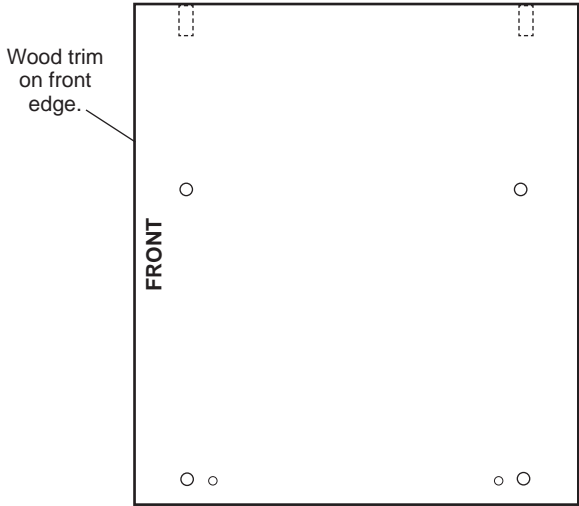
- Read both the Assembly Instructions and Finishing Hints completely before beginning.
- Store the parts: 1) in their box; 2) in a dry place; 3) in temperatures ranging from 40° to 90°. (Not on a cold, possibly damp, cement floor.)
- Inspect your furniture periodically for any loose glue joints or screws, or any other problem which may be affecting the stability of your furniture. Tighten or repair as needed.

Production Code:

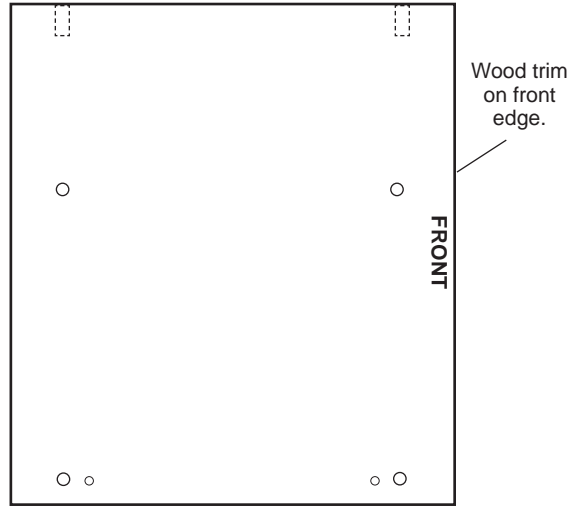
Rev. 11/07

# 712Wb TV/VCR – Parts List

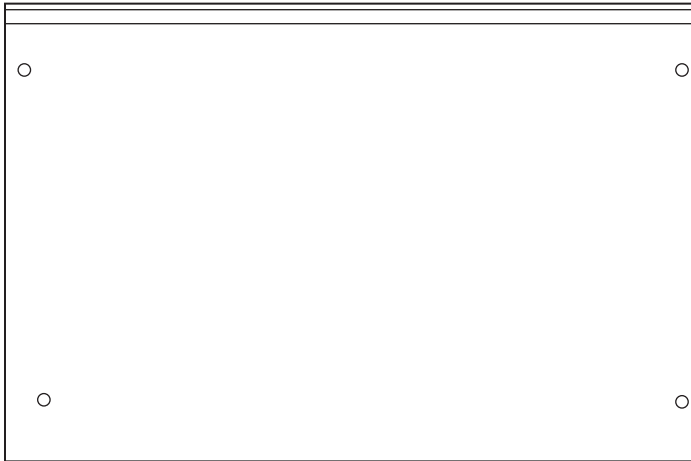
BEFORE BEGINNING ASSEMBLY,  
check that the quantities of the parts received match those on the parts list below.



**Ab — Left Side Panel — Qty. 1**



**Bb — Right Side Panel — Qty. 1**



**Cb — Top — Qty. 1**

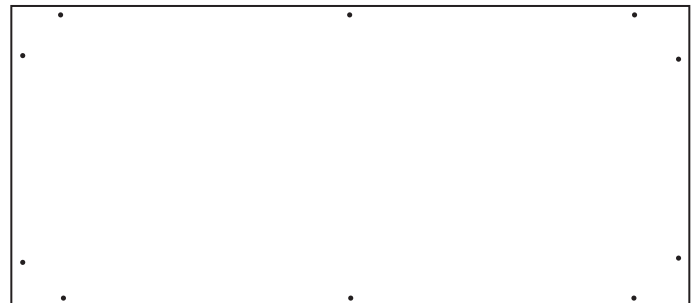
Wood trim on front edge.



**Db — Center Shelf — Qty. 1**

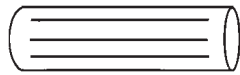


**Eb — Bottom Shelf — Qty. 1**



**F — Back — Qty. 1**

# 712Wb TV/VCR Unit – Parts List *(continued)*



G — Dowels — Qty. 12



II — Caster — Qty. 4



HH — #10x1½" Antique Brass  
Screw — Qty. 4



J — #8x5/8" Pan Head Screw — Qty. 16

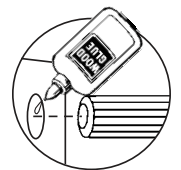
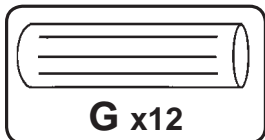


L — #6x5/8" Philtruss Screw — Qty. 10

## 712Wb TV/VCR Unit ASSEMBLY INSTRUCTIONS

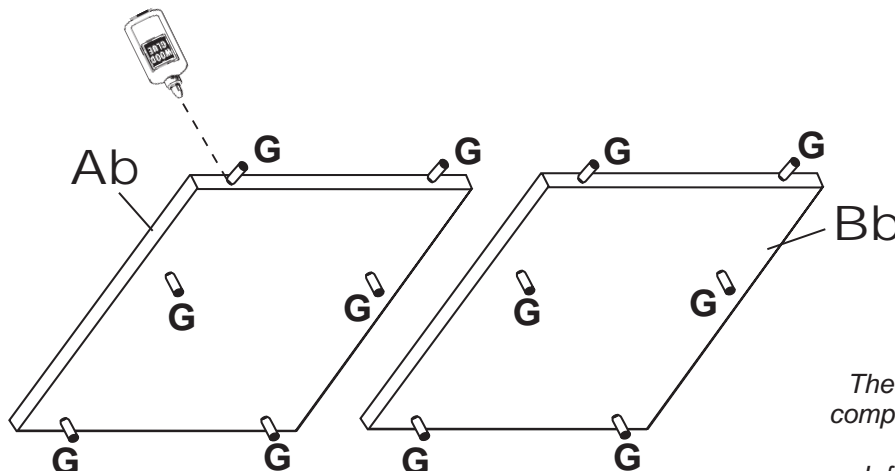
### TOOLS REQUIRED:

Phillips head screwdriver, hammer, tape measure, wood glue, 3/32" drill bit and drill.



**GLUE ALL  
DOWELS IN  
THIS STEP**

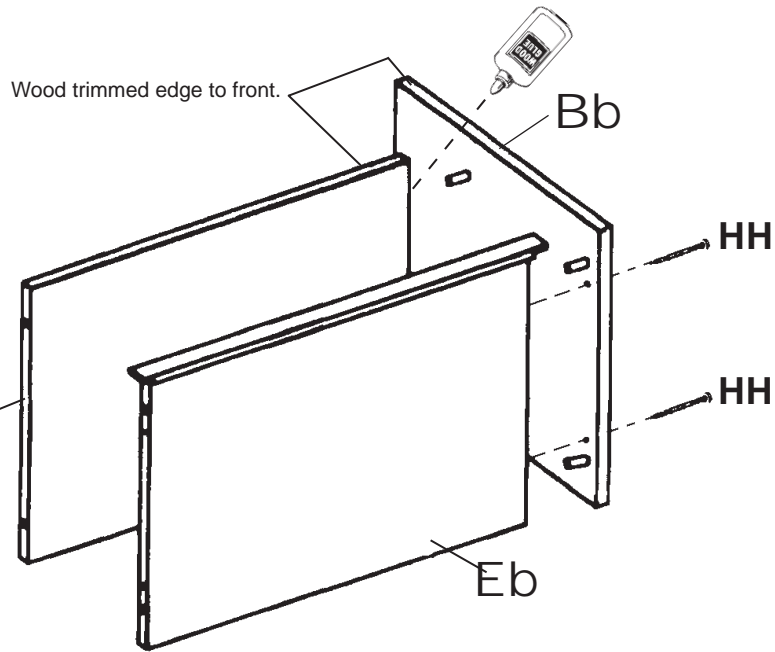
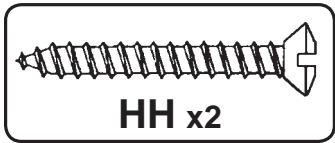
FIG. 1



*The side panels have a  
compression stamp on the  
bottom edge:  
L for Left, R for Right*

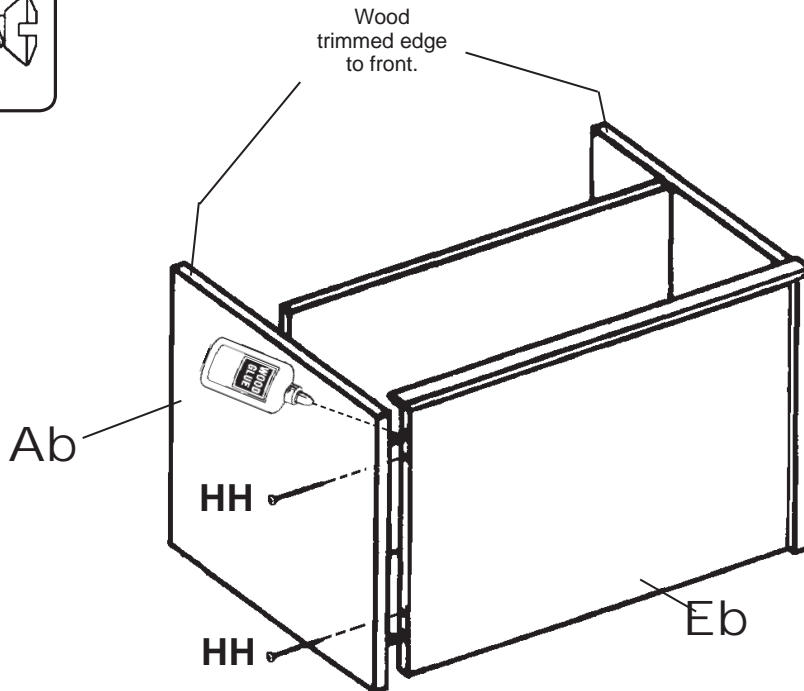
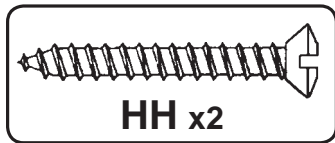
### READ ENCLOSED GLUING HINTS

- 1) Spread glue evenly in the holes and insert Dowels (G) in each side panel (Ab & Bb), two in top edge and four in flat surface. Tap firmly into place.



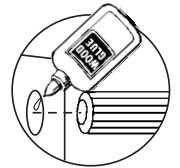
**FIG. 2**

- 2) Spread glue in dowel holes in Center Shelf (Db). Install Center Shelf over dowels in Right Side Panel (Bb).
- 3) Spread glue in dowel holes in Bottom Shelf (Eb). Install Bottom Shelf over dowels and attach with #10x1½" Antique Brass Screws (HH) into Right Side Panel (Bb).

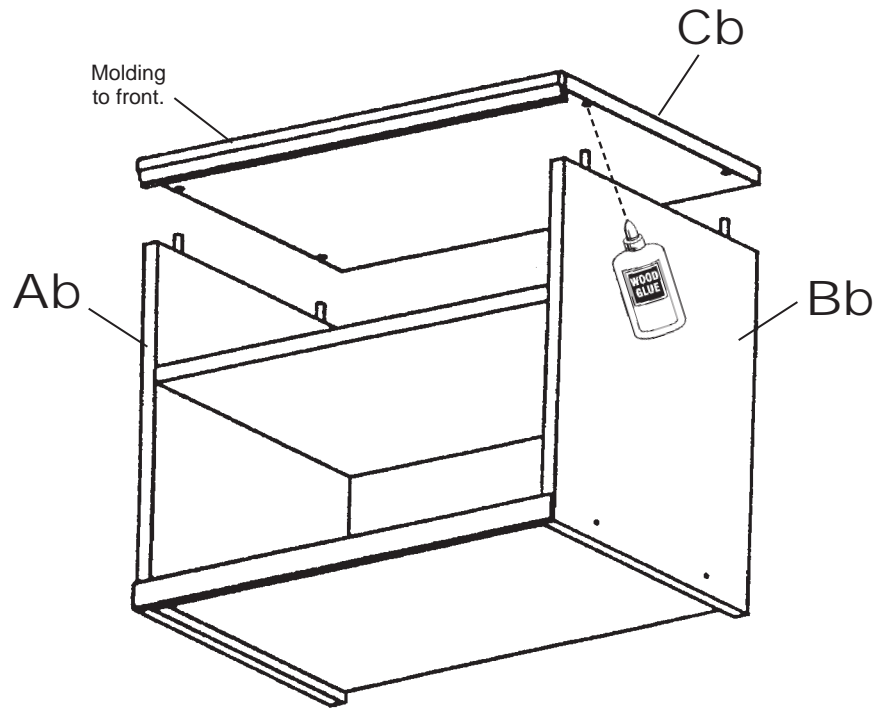


**FIG. 3**

- 4) Attach Left Side Panel (Ab) to center and bottom shelf.

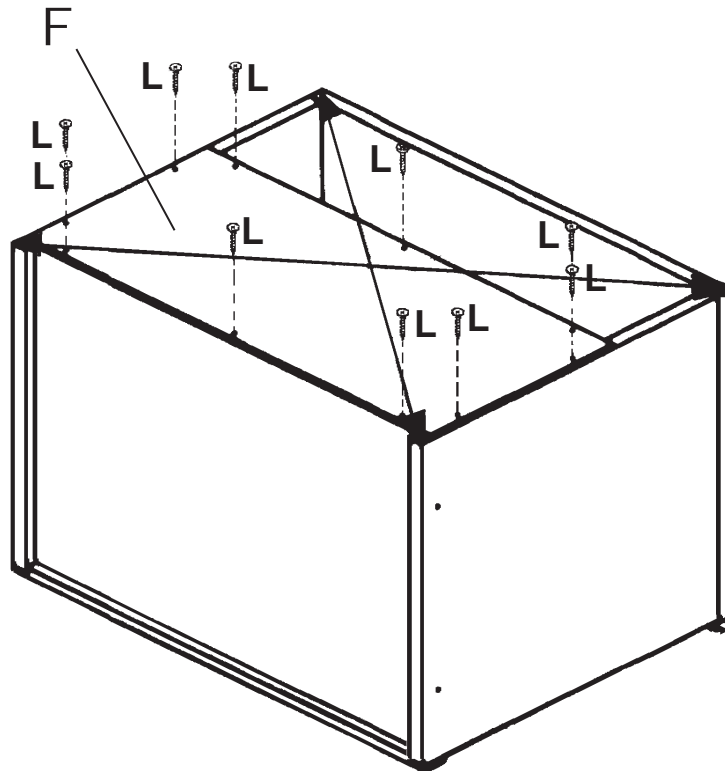
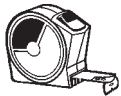
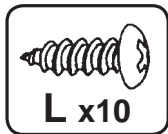


**GLUE ALL  
DOWELS IN  
THIS STEP**



**FIG. 4**

- 5) Spread glue in dowel holes in Top (Cb). Install top over dowels in each side panel.



**FIG. 5**

- 6) Ensure unit is square by measuring diagonally from top to bottom. Measurements should be equal. Attach Back (F) with #6x5/8" Philtruss Screws (L).

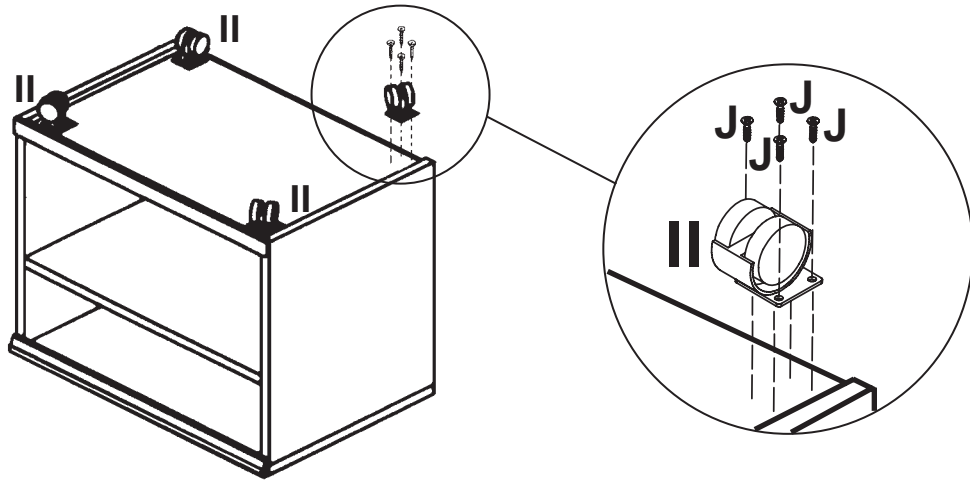
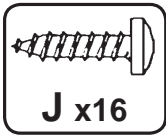


FIG. 6

- 7) With unit upside down, place a Caster (II) in each corner and mark the location of the holes on the bottom shelf. Drill a 3/32" hole 1/2" deep at each mark and attach casters with #8x5/8" Pan Head Screws (J).





# Finishing Hints

## Choosing the Finish:

1. Choose a finish that will meet your expectations for the product you are finishing. Are you matching existing furniture or do you want a “natural” finish? Is the piece to be functional, decorative or both? The answers to these questions may affect the type of finish you choose.
2. Use products of the same brand to ensure compatibility of products.
3. **ALWAYS** follow the stain manufacturer’s instructions. Alder is a porous hardwood and often looks best when following the finishing directions for softwoods
4. We recommend using a wood conditioner under oil base stains.
5. Work in a well ventilated and well lit area.

## Getting Started

1. **Assembly Instructions may contain special finishing information for that item.** Read both the Assembly Instructions and these Finishing Hints completely before beginning.
2. Sand the entire piece, using #220 grit sandpaper. Sand with the grain of the wood on flat surfaces and opposite the grain on turnings. Some parts are plywood. Be careful not to sand through the veneer. End grain (table top ends, seat edges, grooves on turnings, etc.) accepts more stain. Extra sanding in these areas with a #320 grit sandpaper will reduce stain absorption, creating a more evenly stained piece.
3. When sanding is completed, wipe the surface of your furniture with a cloth or tack rag. Make sure the item is free of dust before proceeding.

## Staining

1. Read and follow label directions. Stir stain well before starting.
2. Test stain on an inconspicuous spot on your project, or use the sample chip if one is provided. The sample chip must be sanded in the same way as your furniture kit to ensure the piece will accept the stain similarly. Put at least one coat of your top coat over the stain sample, as it also affects the look of the stain. **Test every type of wood that is in your kit.** Some of our products include more than one type of wood, which may react differently to the stain color. Sample chips for the different woods may be included. It may be necessary to add a second coat of stain to lighter woods to match the darker woods in your kit.

## Basic Equipment:

- |  |   |  |
|--|---|--|
| <input type="checkbox"/> Rubber gloves | <input type="checkbox"/> Tack cloth                       | <input type="checkbox"/> #220 & #320 sandpaper |
| <input type="checkbox"/> Rags          | <input type="checkbox"/> Drop cloth                       | <input type="checkbox"/> Mineral spirits       |
| <input type="checkbox"/> Paper towels  | <input type="checkbox"/> Paint brushes (bristle and foam) | <input type="checkbox"/> Masking Tape          |
| <input type="checkbox"/> Q-tips        |   |  |

3. Apply stain with a poly brush or lint-free cloth. Apply stain over a small area and wipe off excess. Working in small areas will make the color easier to control.
4. Q-tips are ideal for hard to reach areas.
5. Allow to dry thoroughly before proceeding.

## Applying the Top Coat:

**No top coat is required if using paint.**

1. **Always read and follow all label directions.** Stir your finish coat gently, **do not shake.** It will create bubbles that are hard to remove.
2. **All surfaces** (including the underside of table tops and inside drawers) **must be sealed with at least one layer of a top coat.** This will help minimize wood swelling, shrinkage, warping and cupping due to changes in moisture content or temperature.
3. We recommend that you **apply a minimum of two coats when using polyurethane or varnish (especially on all table top and work surfaces).** Sand lightly between coats using a #320 grit sandpaper or 00 steel wool for the smoothest possible finish.
4. Some water-based finishes tend to raise the grain slightly. This can be easily controlled with this sanding step. However, do not use steel wool when using water-based finishes. Strands of steel fiber caught in the wood can cause rust spots when coated with any water-based product.

## Painting:

1. For best results when painting, first coat the wood with a primer. An oil based primer would be best for a smooth finish. If you do not wish to use a solvent based primer, a water based primer would work almost as well.
2. Buy a quality brand paint. You may use a satin, semi-gloss, or gloss sheen. Apply a second coat for a smooth finish. Lightly sand between coats using a #320 grit sandpaper, so that the second coat will bond well. Repeat as desired.
3. Since there is such a variation between paint manufacturers, refer to your paint supplier for specific advice on using the paint that you purchase.