

McKenzie Twin Storage Beds

Assembly Instructions

Model #

1300AUF

McKenzie Twin Storage Bed

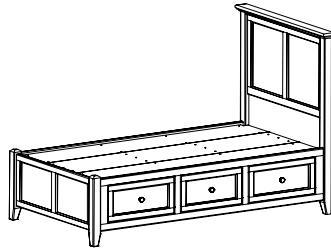

Model #

1359AUF

McKenzie Twin Bookcase Storage Bed

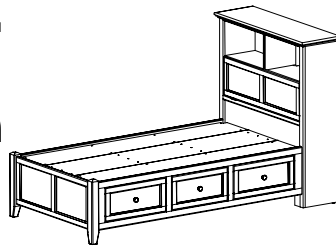

IMPORTANT NOTES:

- For normal household use only. *Not* recommended for commercial use.
- Remove items before you move this unit.
- Do not overload the drawers.
- Before you load or move this unit, tighten all screws and supports.
- Before you begin your project, completely read the Assembly Instructions and Finishing Hints.
- Store this item: 1- in its box; 2- in a dry place; 3- in temperatures that range from 40°F to 90°F (not on a cold and possibly damp cement floor).
- Periodically inspect your furniture for any loose glue joints, screws or any other problem that might affect the stability of your furniture. Tighten or repair as needed.
- This assembly requires two people.

DESIGN SUBJECT TO CHANGE WITHOUT NOTICE

Congratulations!

This fine piece of furniture will make a gorgeous addition to your home. For the best results, read the Assembly Instructions and Finishing Hints before you begin your project.



CALL US FIRST! Do not return this item to the store

Service Policy: We will replace any part that is defective, missing or damaged during assembly. For a replacement part, directly contact Whittier Wood Products customer service department by phone, fax, mail or email.

Hours: Our friendly customer service staff can be reached Monday-Friday 7:00 a.m. to 5:00 p.m. (Pacific Time). You may leave a message 24 hours a day, seven days a week.

To Order: Provide the furniture model number (upper portion of this page), the part letter, production code, quantity needed, reason for replacement and your full name, address and telephone number.

Parts ship from our Eugene, Oregon factory within one or two business days from the time we receive your request. Please allow five to ten business days for delivery.

800-653-3336 • Outside the U.S. or Canada: 541-687-0213 • Fax: 541-687-2060
www.whittierwood.com • P.O. Box 2827 • Eugene, Oregon 97402, U.S.A.

**Whittier
Wood**
FURNITURE

P.O. Box 2827
Eugene, OR 97402 USA

Production Code:















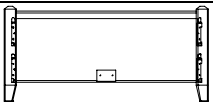

VN

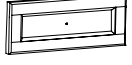
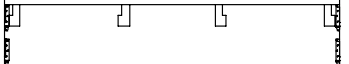
03/12

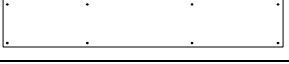
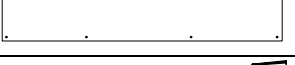







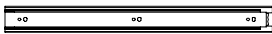

**1300AUF McKenzie Twin Storage Bed;
1359AUF McKenzie Twin Bookcase Storage Bed**
Parts List

Please identify the parts and check that quantities received match those on this list.
If you need to replace a part, refer to the following letter and part name.

1301AUF Footboard, Pedestal and Side Panel Kit (x1)

Part	Description	Quantity
B	Left Bracket (attached) 	6
C	Right Bracket (attached) 	6
D	#8 x 1" Black Screw (inserted) 	48
I	#8 x 7/8" Lo-Profile Screw (inserted) 	16
V	#8 x 1-1/4" Black Screw (inserted) 	60 (40 inserted)
YB	Footboard Assembly 	1
YC	Pedestal Kit 	1
YD	Small Drawer Box (assembled) 	1
YE	Large Drawer Box (assembled) 	2
YF	Small Drawer Face (attached) 	1
YG	Large Drawer Face (attached) 	2
YH	Side Panel 	1
YI	Trestle with T-Nuts 	4
YJ	Center Deckboard 	1
YK	Notched Deckboard (not attached) 	1
YL	Attached Deckboard (attached to pedestal) 	1
YM	Foot Assembly 	2
YN	Foot Bracket (attached) 	2
YO	Adjustable Glide (installed) 	2
YP	Knob (attached) 	3
YQ	#8 x 1-1/2" Machine Screw (installed) 	3



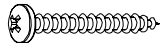

**1300AUF McKenzie Twin Storage Bed;
1359AUF McKenzie Twin Bookcase Storage Bed**
Parts List

Part	Description		Quantity
YR	Drawer Slides (pre-installed sets)		3
YS	#6 x 1/2" Philtruss Screw		26 (18 inserted)
YT	#6 x 3/4" Philtruss Screw (inserted)		18
YU	1/4" x 1-3/4" Hex Bolt		8
YV	Washer		8
YW	90° Bracket (2 holes)		2
YX	90° Bracket (4 holes)		1
YY	Insert Nut (inserted)		6
YZ	T-Nut (inserted)		8
ZA	#8 x 1-5/8" Black Screw (inserted)		18
ZB	#8 x 2" Black Screw (inserted)		16
ZC	#8 x 20mm Pan Head Screw (inserted)		8

Please note this Assembly Instruction is for either the Twin Storage Bed or the Twin Bookcase Storage Bed. The Parts list for each headboard follows on pages 4 and 5.

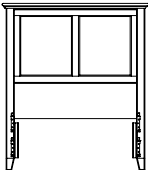



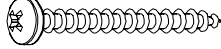







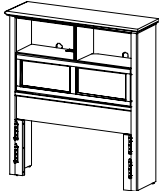
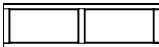
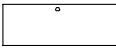



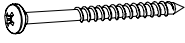

**1300AUF McKenzie Twin Storage Bed;
1359AUF McKenzie Twin Bookcase Storage Bed**
Parts List

1302AUF Twin Headboard Kit (x1)

Part	Description	Image	Quantity
A	Headboard Assembly		1
B	Left Bracket (attached)		2
C	Right Bracket (attached)		2
D	#8 x 1" Black Screw (inserted)		16
ZD	#12 x 2-1/2" Pan Head Screw (inserted)		6

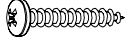
**1300AUF McKenzie Twin Storage Bed;
1359AUF McKenzie Twin Bookcase Storage Bed**
Parts List

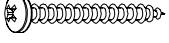
1361AUF Bookcase Headboard Kit (x1)

Part	Description		Quantity
B	Left Bracket (attached)		2
C	Right Bracket (attached)		2
D	#8 x 1" Black Screw (inserted)		16
E	Bookcase Headboard Assembly		1
F	Assembled Door (attached)		1
G	False Bottom		2
H	Power Strip (installed)		1
I	#8 x 7/8" Lo-Profile Screw (inserted)		4
J	Wire Clip Screw (attached)		3
K	Door Stay (attached)		1
L	#6 x 5/8" Undercut Screw (inserted)		8
M	Door Stay Support (attached)		1
N	#6 x 1-1/4" Black Pan Head Screw (inserted)		3
O	Hinge (installed)		3
P	#6 x 5/8" Flat Head Screw (inserted)		18
Q	Magnetic Catch Kit (attached)		2 sets
R	#6 x 5/8" Philtruss Screw (inserted)		9
S	Corner Brace (attached)		2
T	Large Adjustable Glide (installed)		2
U	#8 x 5/8" Pan Head Screw (inserted)		8
V	#8 x 1-1/4" Black Screw (inserted)		25
W	#8 x 2-1/4" Black Screw (inserted)		6
X	#8 x 1-1/4" Pan Head Screw (inserted)		12
YA	Tack Glide (attached)		4

**1300AUF McKenzie Twin Storage Bed;
1359AUF McKenzie Twin Bookcase Storage Bed**
Assembly Instructions



This assembly requires two people.

Tools Required: Phillips screwdriver, 7/16" open end or box end wrench.

1. Remove the Foot Assemblies (YM) from the back of the Footboard (YB) as seen in Figure 1 and place them off to the side.

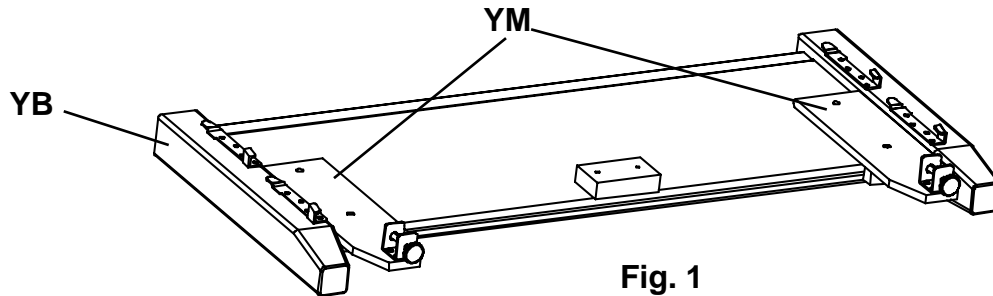

Fig. 1

2. The orientation of the drawer opening will be based on facing the backside of the footboard. Decide if you want the drawers to open on the left side or the right side of the bed. Figure 2 below shows the drawers opening on the right side. If you want the drawers to open on the left side, move the Footboard (YB) to the opposite end of the Pedestal Kit (YC). To attach the Footboard (YB) to the Pedestal Kit (YC), align the brackets and slide the Pedestal Kit down on to the Footboard (YB). See Figures 2 and 2a.

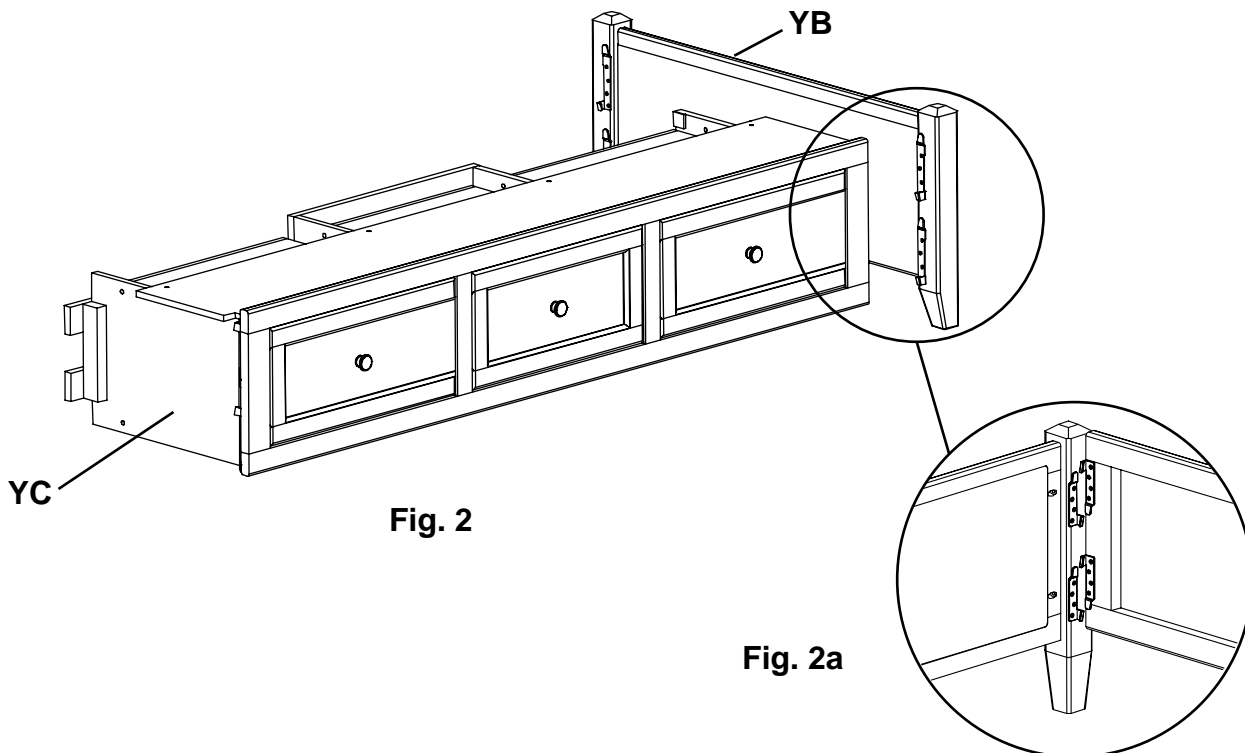
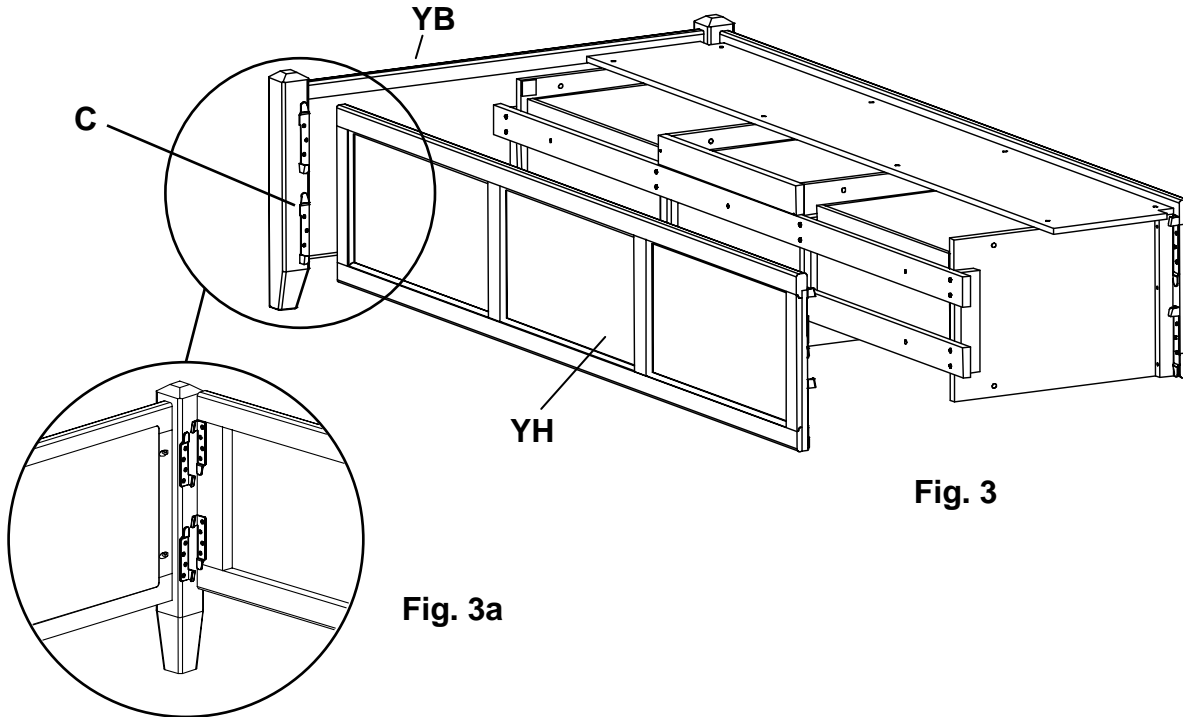

Fig. 2

Fig. 2a

**1300AUF McKenzie Twin Storage Bed;
1359AUF McKenzie Twin Bookcase Storage Bed**
Assembly Instructions

3. To attach the Side Panel (YH) to the Footboard (YB), align the brackets and slide the Side Panel (YH) down on to the Footboard (YB). See Figures 3 and 3a.



4. Move your Twin Headboard (A) or Twin Bookcase Headboard (E) into position. Make sure the drawers are opening on the side you desire. If you are satisfied, align and slide the brackets of the Bed Assembly on to the brackets of the Headboard (A or E). If you are not satisfied with the drawer position, remove the Footboard (YB) from the Bed Assembly and install at the opposite end. Attach the Headboard (A or E). See Figures 4 or 4a.

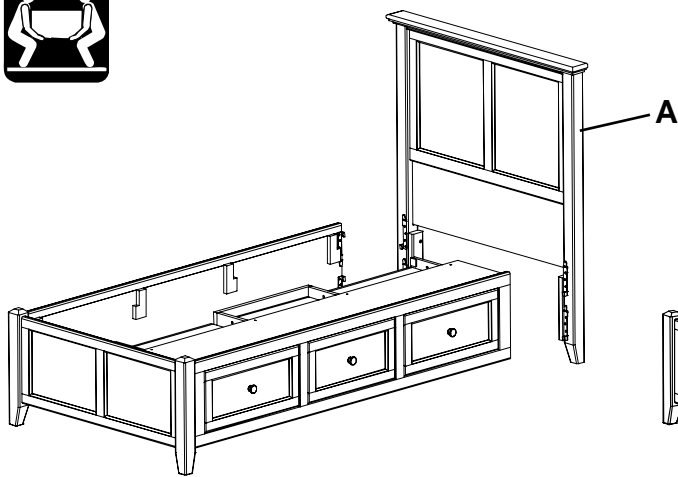

Fig. 4

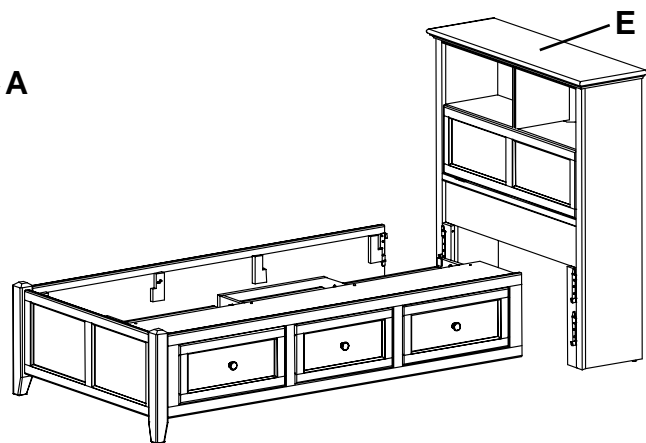
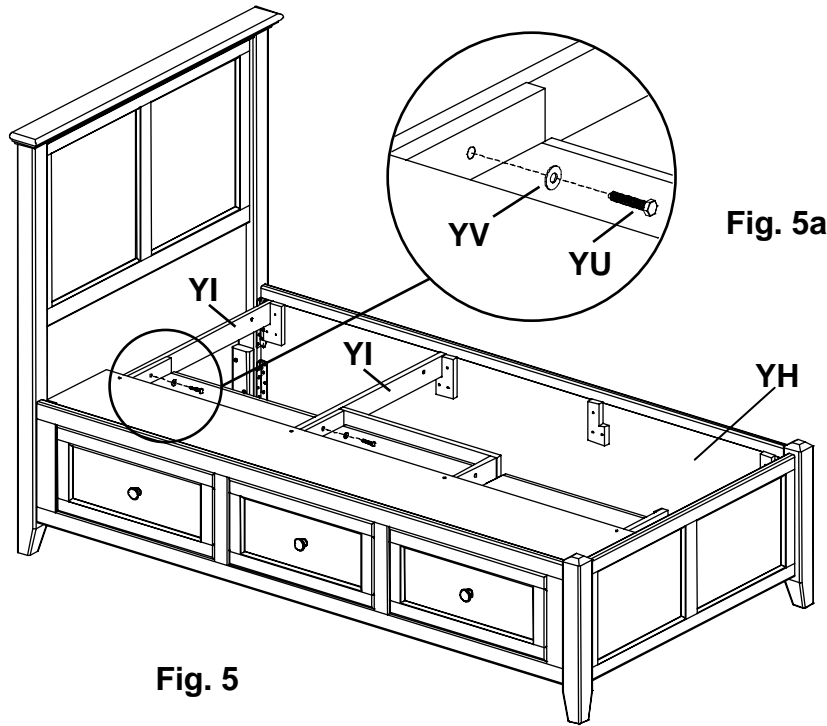



Fig. 4a

**1300AUF McKenzie Twin Storage Bed;
1359AUF McKenzie Twin Bookcase Storage Bed**
Assembly Instructions



5. Place one end of a Trestle with T-Nuts (YI) facing towards the Headboard, behind the rib in the pedestal closest to the Headboard. Place the other end of the Trestle into the notched bracket in the Side Panel (YH). See Figure 5. Place a Washer (YV) onto a 1/4" x 1-3/4" (YU) and insert through the holes in the rib and Trestle as seen in Figure 5a, threading into the T-Nut. Repeat for a second Trestle with T-Nuts (YI).

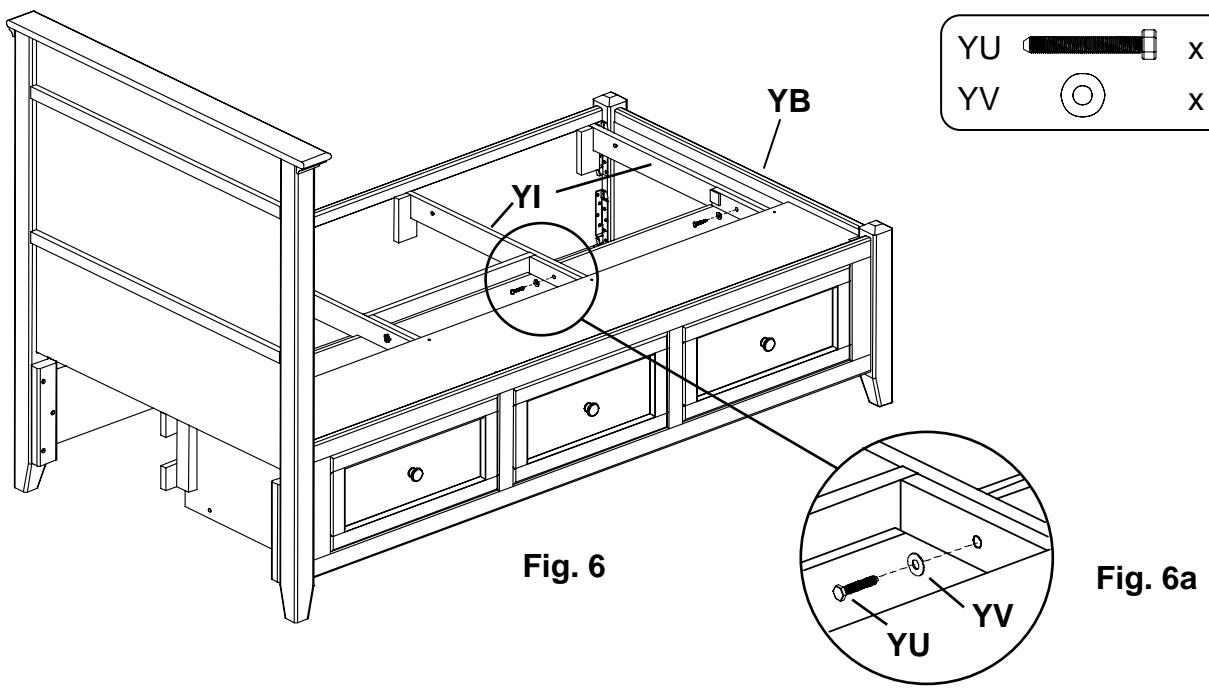

YU		x 2
YV		x 2

6. Attach two more Trestles with T-Nuts (YI) that face the Footboard (YB) as seen in Figure 6 and 6a.



YU		x 2
YV		x 2

**1300AUF McKenzie Twin Storage Bed;
1359AUF McKenzie Twin Bookcase Storage Bed**
Assembly Instructions

7. Using the 90° brackets with two holes (YW) attach the two middle Trestles to the notched brackets in the Side Panel (YH) with four #6 x 1/2" Philtruss Screws (YS). See Figures 7 and 7a.

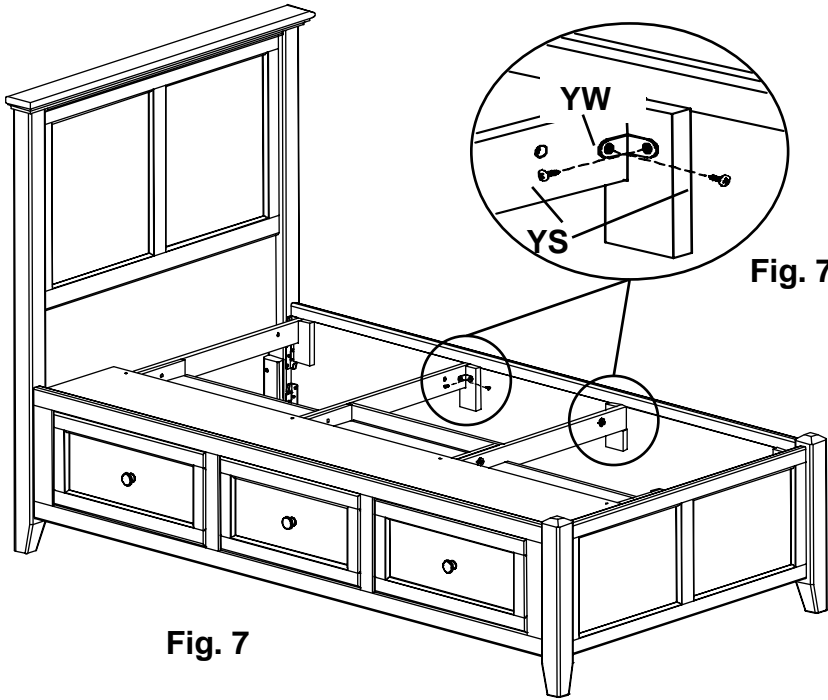



YW		x 2
YS		x 4

Fig. 7

8. Locate the holes and T-nuts in the horizontal stretchers of the Pedestal Assembly. In the sets of stretcher holes nearest the Headboard, attach the two Foot Assemblies (YM) to the stretchers using four 1/4" x 1-3/4" (YU) and four Washers (YV). See Figure 8 and 8a.



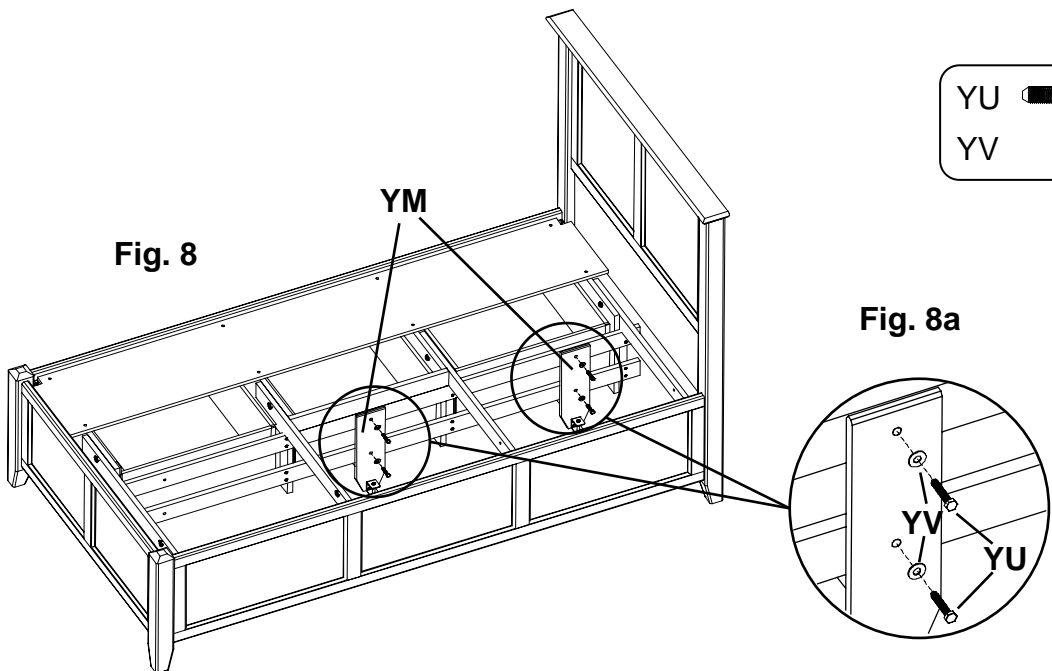

YU		x 4
YV		x 4

Fig. 8

Fig. 8a

**1300AUF McKenzie Twin Storage Bed;
1359AUF McKenzie Twin Bookcase Storage Bed**
Assembly Instructions

9. Facing the Footboard, attach the lower brace of the Pedestal Assembly to the Footboard with the 90° bracket with four holes (YX) and four #6 x 1/2" Philtruss Screws (YS). See Figures 9 and 9a.

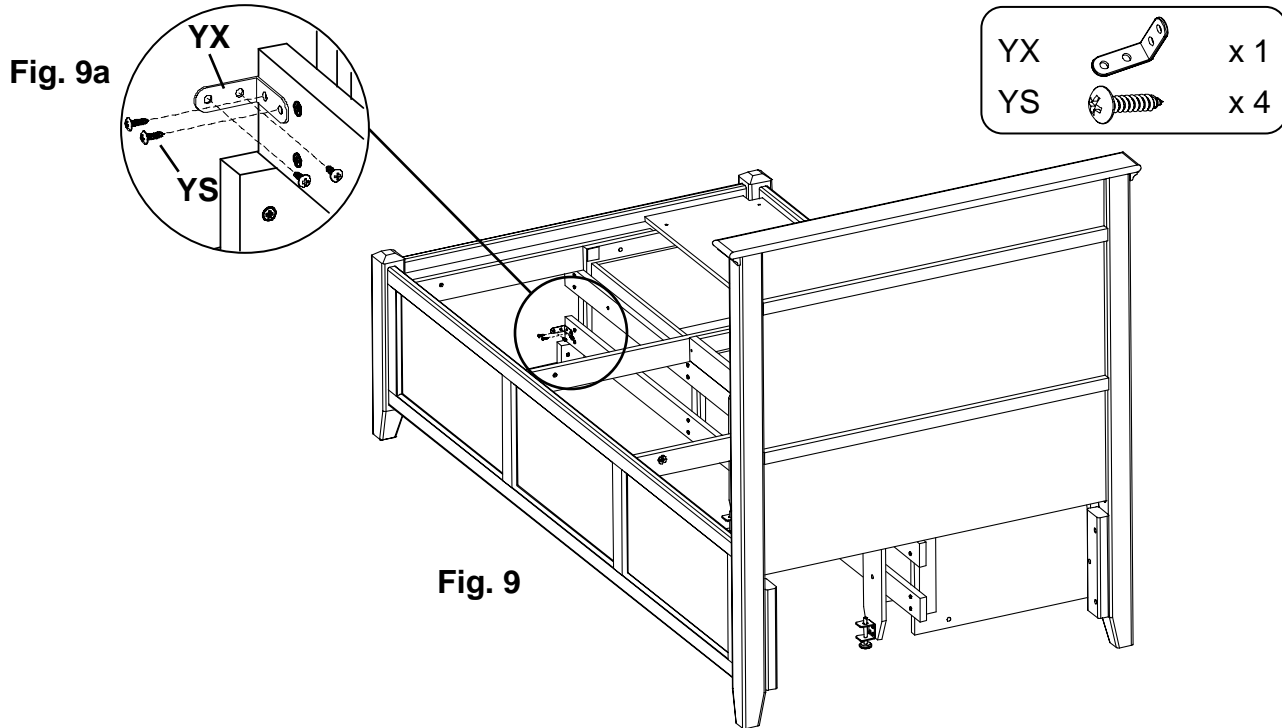

10. Move the Bed Assembly to its final destination. Adjust the Glides (YO) in the bottoms of the Foot Assemblies (YM) so that they touch the floor and bear weight. See Figure 10.

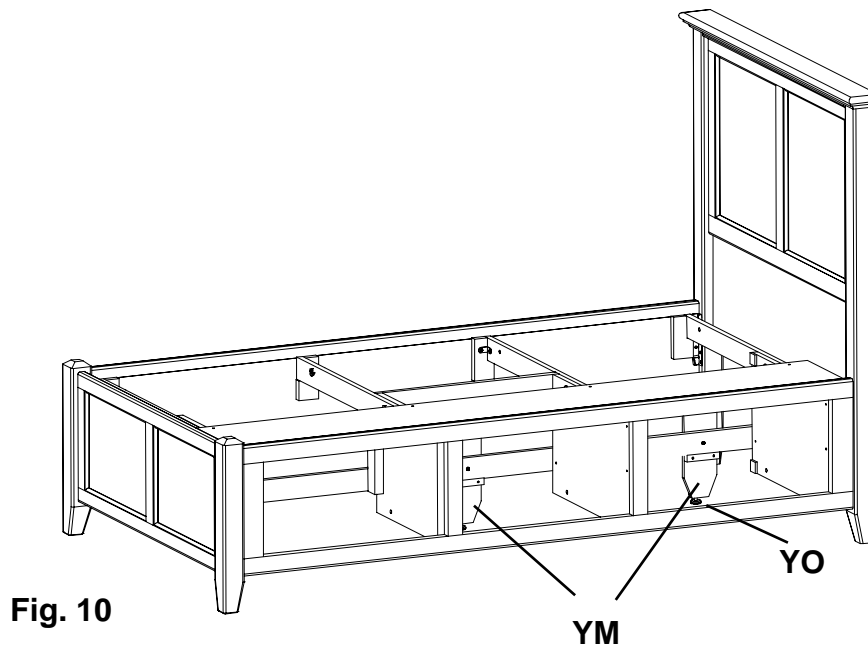

**1300AUF McKenzie Twin Storage Bed;
1359AUF McKenzie Twin Bookcase Storage Bed**
Assembly Instructions

11. If you have a Bookcase Headboard, stand in the open area of the assembly and reach behind the bookcase front legs to find the Large Adjustable Glides (T). Using a slotted screw driver, rotate the Large Adjustable Glides (T) clockwise until they bear weight. See Figures 11, 11a and 11b.

This is important if the bookcase headboard sits upon a carpet tack strip.

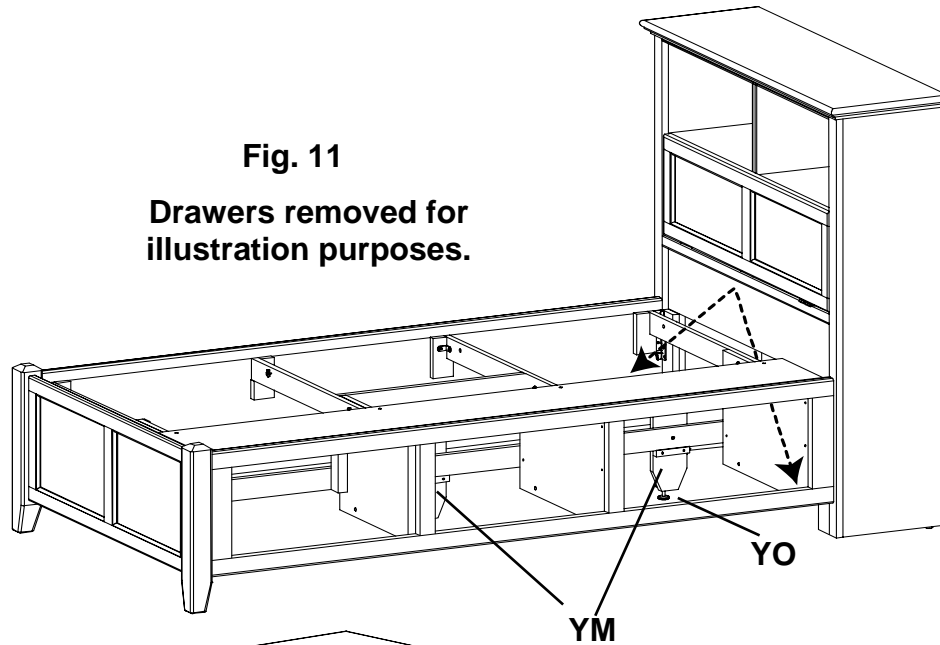

Fig. 11a

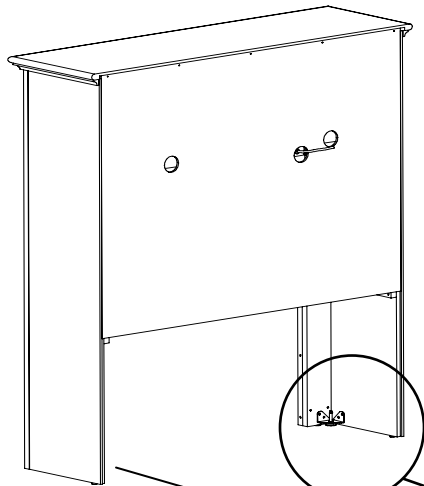
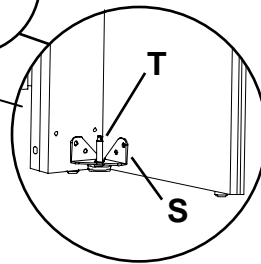

Fig. 11b

The top of the Large Adjustable Glide (T) is slotted.



**1300AUF McKenzie Twin Storage Bed;
1359AUF McKenzie Twin Bookcase Storage Bed**
Assembly Instructions

12. To make sure the bed is square, measure the distance between opposing corners. If one of the measurements is larger tap on a footboard leg until the measurement is equal. See Figure 12.

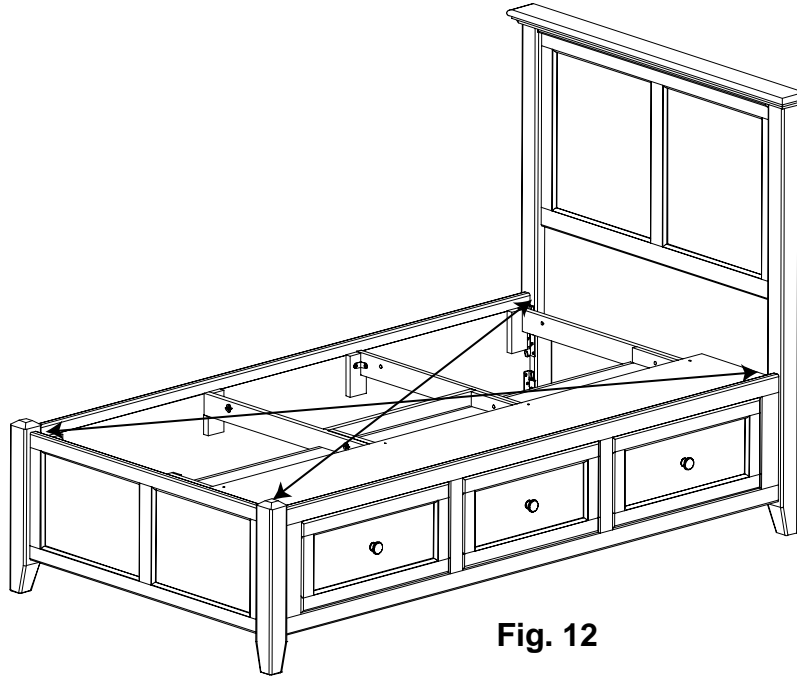

Fig. 12

13. Place the Center Deckboard (YJ) in the middle and with the notches facing out place the Notched Deckboard (YK) as shown in Figure 13. There should be a small gap between each deckboard. Secure with twenty #8 x 1-1/4" Black Screws (V).

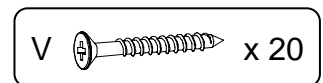
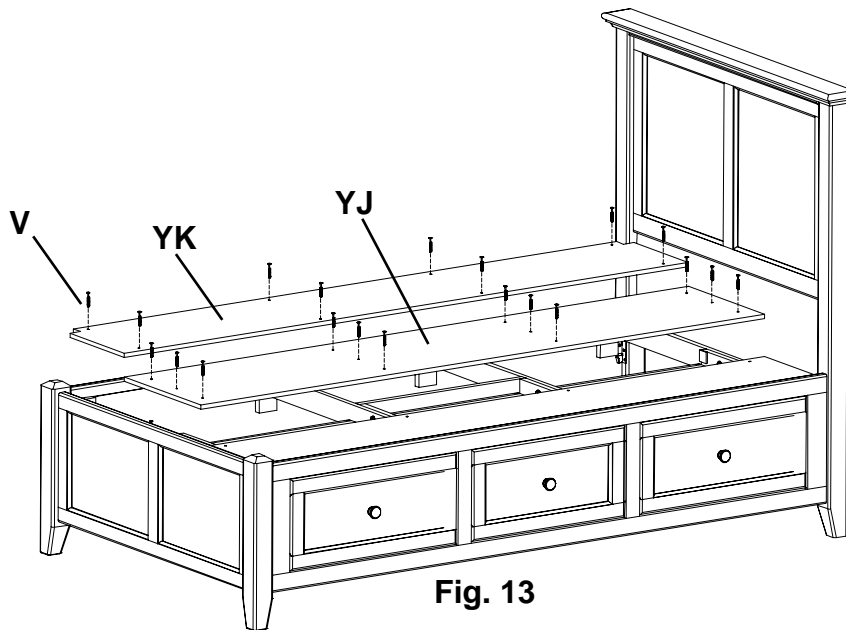

Fig. 13

**1300AUF McKenzie Twin Storage Bed;
1359AUF McKenzie Twin Bookcase Storage Bed**
Assembly Instructions

Steps 14 – 15 are for the Bookcase Headboard Only

14. To adjust the brake tension on the Door Stay (K) turn the screw on the Door Stay clockwise to loosen or counterclockwise to tighten. See Figures 14 and 14a.

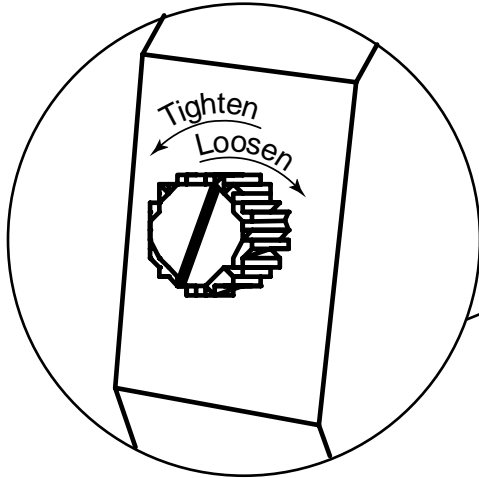

Fig. 14a

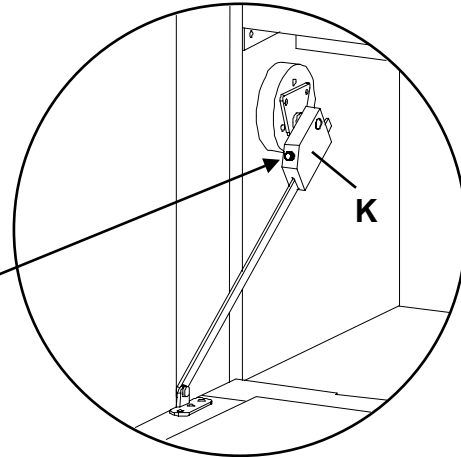

Fig. 14

15. Unwrap the False Bottoms (G) and place them on top of the rails in the Headboard Assembly (E). Make sure the finger holes face forward as shown in Figure 15. After you have placed your electronics inside the cubbies, use the Wire Clips (J) on the underside of the cubbies to secure the wires. Close the door tightly making sure the magnetic catches and plates securely touch.

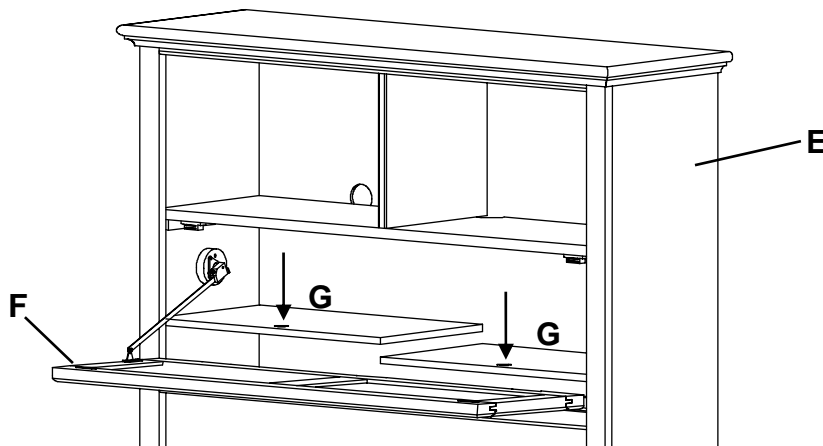

Fig. 15

Whittier Finishing Hints

Checklist of materials

- | | | |
|---|--|--|
| <input type="checkbox"/> Rubber gloves | <input type="checkbox"/> Tack cloth | <input type="checkbox"/> #220 & #320 sandpaper |
| <input type="checkbox"/> Lint-free rags | <input type="checkbox"/> Drop cloth | <input type="checkbox"/> Painter's tape |
| <input type="checkbox"/> Paper towels | <input type="checkbox"/> Stain brushes (poly bristle and foam) | <input type="checkbox"/> Wood glue |
| <input type="checkbox"/> Cotton swabs | | |

Getting started

Assembly Instructions may contain special finishing information or gluing requirements for that item.

Completely read both the Assembly Instructions and these Finishing Hints before you begin your project.

Choosing the finish: Ask your retailer for advice on how to finish bare wood. Choose a finish that meets your expectations for the end use of the product. Will you use it as a work surface as on a desk or kitchen island? Are you matching a finish on existing furniture? The answers to these questions may affect the type of finish you choose.

Where to work: Choose an area that has good light and is well ventilated, warm and dry. If the work area is cold and damp, the wood finishing products may require a longer drying time than the labels indicate. Do not work in a dirty or dusty area – dirt and/or dust can embed in the finish.

Gluing hints

These are general hints. Refer to the Assembly Instructions for detailed information on how to glue your specific product. Use wood glue such as Elmer's Wood Glue, Titebond Wood Glue or the equivalent. Some instructions call for a slow drying epoxy glue. Carefully read the label and instructions of the glue manufacturer. Your unit may not need glue.

1. We strongly recommend that you lay out all the parts and familiarize yourself with how they fit together before assembling with glue. Glue will set up quickly. You can damage parts if you try to reposition any that have been assembled incorrectly.

2. For glue to properly bond, it is very important to apply the wood glue to bare wood. Protect your eyes and blow into holes to clear excess dust. This will help the glue to adhere to a clean surface.
3. If you plan on finishing the product before you assemble it, place painter's tape three-fourths of the way up from the end of a dowel, spindle or tenon. This protects the ends from the finishing product but allows finish application where it will be visible. Finishing products inhibit the bonding properties of wood glue. Remove the tape prior to the final assembly.
4. Avoid getting glue on surfaces to be finished. Most stains or finishes will not penetrate where glue has been spilled. Wet glue can be wiped off with a damp cloth. Follow with a light sanding of the area to ensure a proper finish.
5. It is important to apply an even coat inside holes and slots. Use a small dowel, pencil or cotton swab to spread glue evenly around the inside of the holes. Do not over glue. The tight fit of the spindles or dowels in the holes can cause glue to be pushed to the bottom of the hole. If too much glue is used it will fill the holes and not allow the spindle or dowel to be fully inserted.
6. Glue usually takes several hours to cure or harden but it will set up or grab in several seconds. Once you begin final assembly, proceed quickly.

Finishing hints

1. Use products of the same brand to ensure compatibility. It is not recommended to mix solvent based and water based finishes. *Always read and follow all label directions on the can.*
2. Alder is a porous hardwood and often looks best when following the finishing instructions for softwoods.
3. Use a wood conditioner under oil base stains.

Preparing the surface

1. Sand each piece with #220 grit sandpaper. Sand with the grain of the wood on flat surfaces and opposite the grain on turnings. Some parts may be plywood. Be careful not to sand through the veneer. End grain such as table top ends, seat edges and grooves on turnings accept more stain. Extra sanding in these areas with #320 grit sandpaper reduces stain absorption and creates a more evenly stained piece.
2. When sanding is completed, wipe the surface of your furniture with a lint-free rag or tack cloth. Make sure the item is free of dust before you proceed.

Staining

1. Read and follow label directions. Stir the stain well before you start. Stir periodically throughout the duration of the project to maintain uniform color consistency.
2. Test stain on an inconspicuous spot on your project. Put at least one coat of your top coat over the test area as it also affects the look of the stain. *Test every type of wood that is in your kit. These are identified in the Assembly Instructions.* Different types of wood may react differently to the stain color. You might need to add a second coat of stain to lighter woods to match the darker woods in your kit.
3. Apply stain with a poly brush or lint-free cloth. Apply stain over a small area and wipe off excess. Working in small areas will make the color easier to control.
4. Cotton swabs are ideal for hard to reach areas.
5. Allow the stain to dry thoroughly before you proceed.

Applying the top coat

1. *Always read and follow all label directions.* Stir your top coat gently; do not shake. Shaking the can creates bubbles that are hard to remove.
2. All surfaces including the underside of table tops and inside drawers must be sealed with at least one layer of a top coat. This will help minimize wood swelling, shrinkage, warping and cupping due to changes in moisture content or temperature.

3. Apply a minimum of two coats when you use polyurethane or varnish (especially on all table top and work surfaces). After allowing the first coat to dry, sand lightly with #320 grit sandpaper. Remove dust with a lint-free rag or tack cloth. For added protection, apply additional coats. Lightly sand and wipe surface with a lint-free rag or tack cloth between coats.
4. Some finishes tend to slightly raise the grain. This can be easily controlled with a light sanding between coats. Do not use steel wool when you use water-based finishes. Strands of steel fiber caught in the wood can cause rust spots when coated with any water-based product.

Painting

1. Since there is a large variation between paint manufacturers and products, ask your paint supplier for specific advice on how to best use the paint you purchase. Ask them specifically for advice on finishing bare wood.
2. First coat the wood with a primer. An oil based primer works best for a smooth finish. If you do not wish to use a solvent based primer, water based primer works almost as well. However it may raise the wood grain and require additional sanding.
3. Buy quality brand paint in a satin, semi-gloss, or gloss sheen. Apply a second coat for a smooth finish. Lightly sand between coats using with #320 grit sandpaper so that the second coat will bond well. Be sure to use a tack cloth after sanding to remove any residue. Repeat as desired.
4. No top coat is required when using paint.