

Model #

1448AFGSP Pacific Queen Storage Bed

Glazed Spice finish

Assembly Instructions

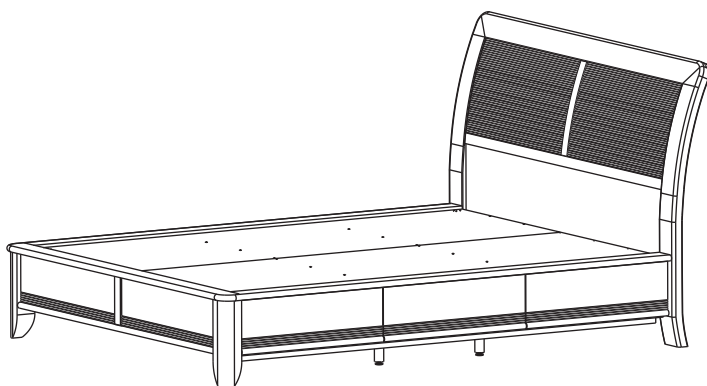

Congratulations!

This fine piece of furniture will make a gorgeous addition to your home. For the best results, start by reading the Assembly Instructions before you begin your project.

**For normal household use only.
NOT recommended for commercial use.**



Unload items from this unit prior to moving.

Before loading or moving this unit, check all screws and supports for tightness.

Do not overload the drawers in this unit.

DESIGN SUBJECT TO CHANGE WITHOUT NOTICE.

**Whittier
Wood**
FURNITURE

P.O. Box 2827
Eugene, OR 97402 USA



CALL US FIRST!

DO NOT RETURN ITEM TO STORE

Service Policy: We will replace parts which are defective, missing or damaged. Please contact Whittier Wood Products customer service department directly (by phone, fax, mail or E-mail) for replacement parts.

Hours: Our friendly customer service staff can be reached Monday-Friday 7:00 a.m. to 5:00 p.m. (Pacific Time). A message can be left 24 hours a day, 7 days a week.

To Order: Provide the complete furniture model number, part letter, production code, quantity needed, reason for replacement and your full name and address along with a telephone number in case we need to contact you.

Parts ship from our Eugene, Oregon factory within 1 or 2 business days from the time we receive the request. Please allow 5-10 business days for delivery.

800-653-3336

Outside U.S. or Canada: 541- 687- 0213

Fax: 541-687-2060 • www.whittierwood.com

Mail: P.O. Box 2827 • Eugene, Oregon 97402, U.S.A

IMPORTANT NOTES:

- Completely read the Assembly Instructions before you begin your project.
- Store the item: 1) in the box; 2) in a dry place; 3) in temperatures from 40° to 90° (not on a cold, possibly damp cement floor).
- Periodically inspect your furniture for any loose glue joints, screws or any other problem that might affect the stability of your piece. Tighten or repair as needed.
- This Assembly requires two people.

Production Code:

VN

07/09

1448AFGSP Pacific Queen Storage Bed — Parts List

Please identify the parts and check that quantities received match what is on this list.
If you need to replace a part, refer to the following letter and item name.

1451AFGSP (x1)

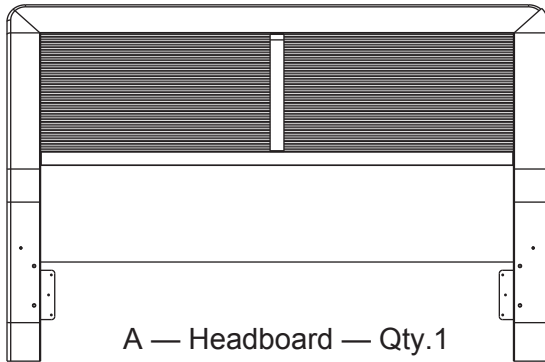

A — Headboard — Qty.1



B — Footboard — Qty.1



D — 5/16" x 2 1/4" Hex Bolt — Qty. 8

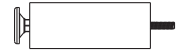

C — Foot Assembly — Qty. 6

M — Adjustable Glide — Qty. 6 (installed)

U — Hanger Bolt — Qty. 6 (inserted)

T — T-Nut — Qty. 6 (inserted)



E — 5/16" Washer — Qty. 8

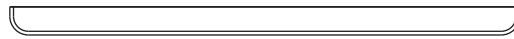

W — Top Cap — Qty. 1 (attached)



G — 1/4" x 1 3/4" Hex Bolt — Qty. 12



H — 1/4" Washer — Qty. 12



I — Barrel Nut — Qty. 2

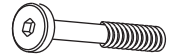

F — 1/4" x 80mm Hex Bolt — Qty. 2

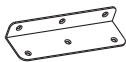

K — Angle Bracket — Qty. 2 (attached)



L — #6 x 3/4" Flat Head Screw — Qty. 12 (6 inserted)

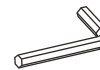

S — Hex Wrench — Qty. 1



J — 9.5mm x 25mm Wood Dowel — Qty. 2

V — Insert Nut — Qty. 8 (inserted)

1449AFGSP (x2)

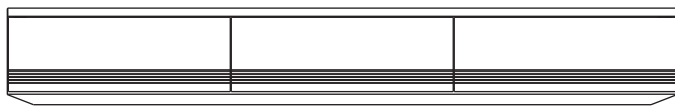

N — Pedestal Kit — Qty.1

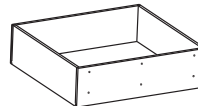

O — Drawer Box — Qty. 3 (assembled)

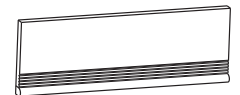

P — Drawer Face — Qty. 3 (attached)

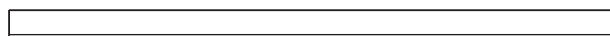

X — Top Cap — Qty. 1 (attached)



Q — #6 x 1 1/4" Black Pan Head Screw — Qty. 8 (inserted)



R — Drawer Slides — Qty. 3 (installed sets)



T — T-Nut — Qty. 9 (inserted)

1448AFGSP Pacific Queen Storage Bed Assembly Instructions

This Assembly Requires Two People

TOOLS REQUIRED: Hex Wrench (provided), Phillips Screwdriver, Slotted Screwdriver
1/2" Wrench, 7/16" Wrench, Tape Measure, Wood Glue, Rubber Mallet or Padded Hammer

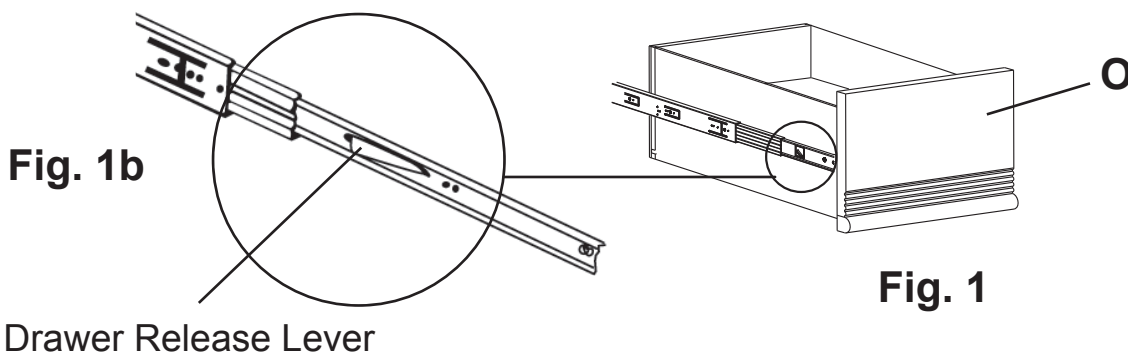

1. Remove the Drawers (O) from the Pedestal Kits (N). To remove the drawers, push up on the left side of the Drawer Release Lever while pushing down on the right Drawer Release Lever. See Figure 1b. Note where each drawer came from to ensure correct re-installation. Positions are marked on the drawer backs.



Fig. 2

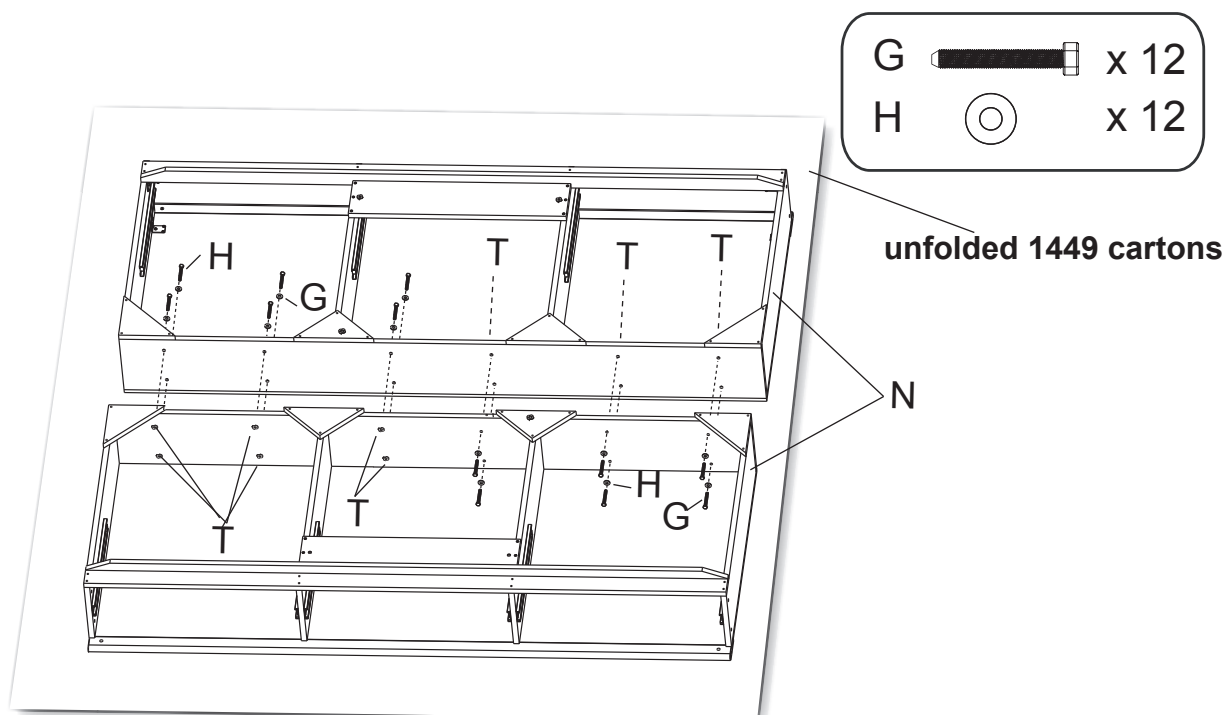

2. To protect your flooring and the surface of the unit, place the Pedestal Kits (N) face-down on top of opened and unfolded 1449 cartons as shown in Figure 2. (When you join the pedestals, carpet fibers can get caught in between the middle supports.) Place twelve washers (H) over twelve $\frac{1}{4}$ " x $1\frac{3}{4}$ " Hex Bolts (G) and thread each through a predrilled hole and into a T-Nut in the middle supports found on each pedestal. Finger tighten each bolt, making sure the pedestals line up with each other. Using a 7/16" wrench, securely tighten each bolt. See Figure 2.

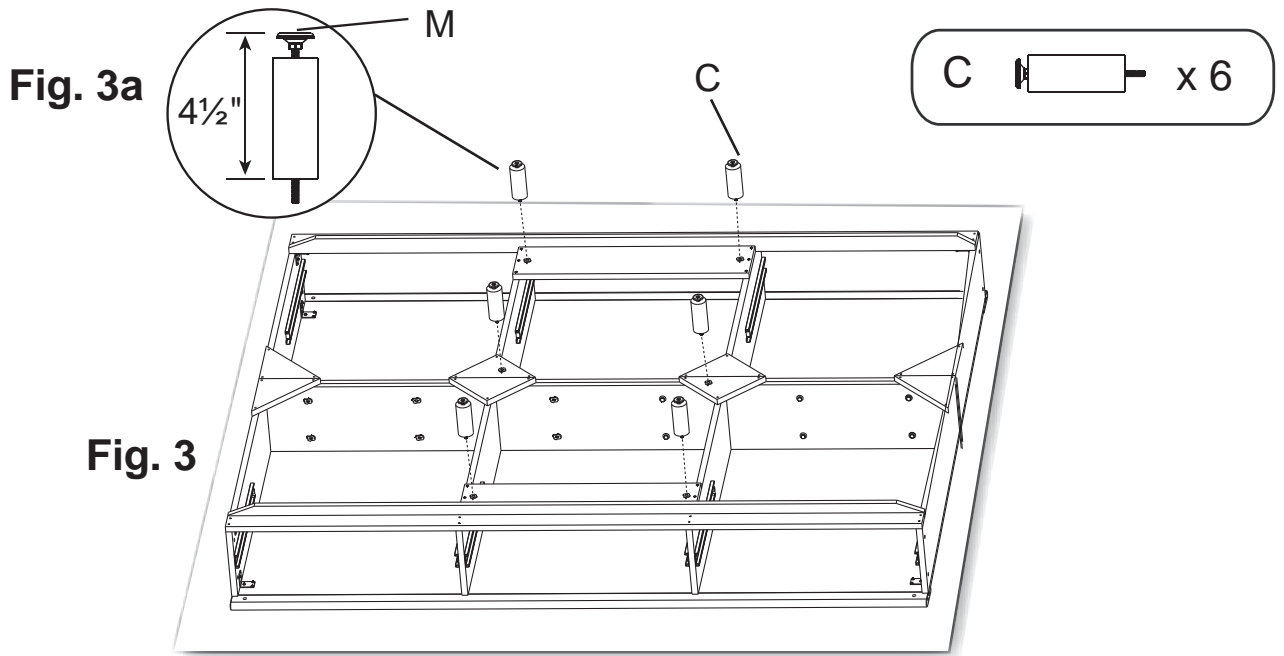

3. Rotate the Adjustable Glides (M) so that the Foot Assemblies (C) are 4½" tall as shown in Figure 3a. Attach the six Foot Assemblies (C) as shown in Figure 3.

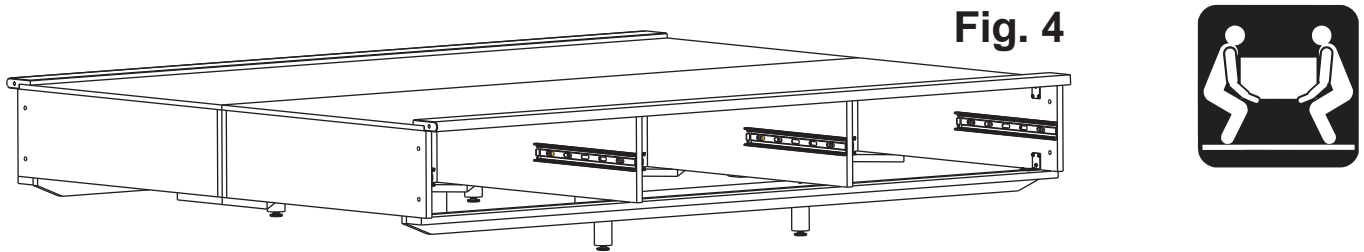

4. This step requires two people to move the bed to its upright horizontal position. Rotate the bed so the deck boards are face-up. **DO NOT PLACE UNDUE PRESSURE ON THE FOOT ASSEMBLIES.** This may cause them to bend or break. See Figure 4.

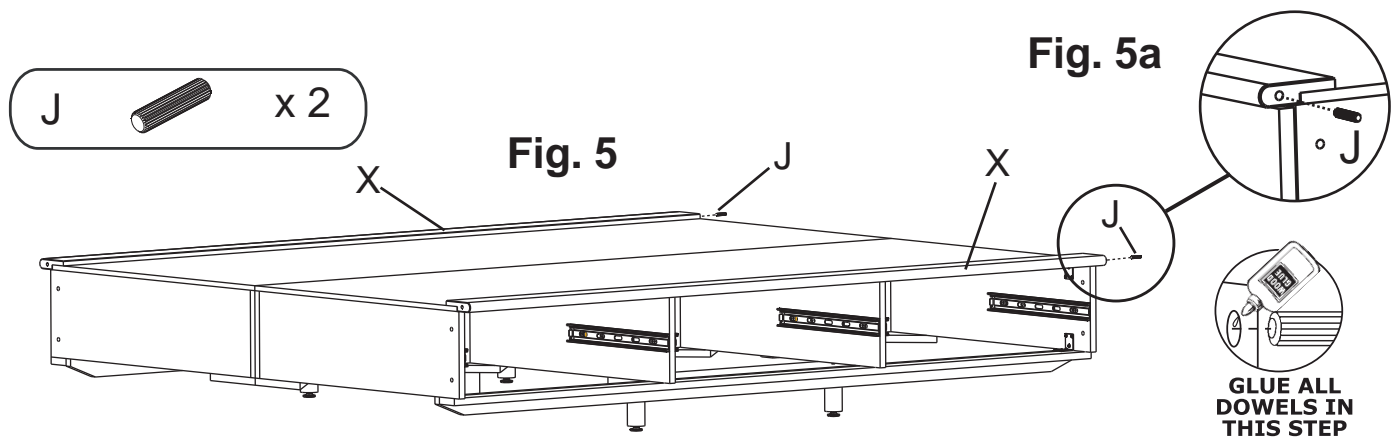

5. Spread a thin film of glue in the dowel holes at one end of the Top Cap (X) of the bed. Insert two dowels (J) and gently tap with a rubber mallet. Quickly wipe away any excess glue. See Figures 5 and 5a.

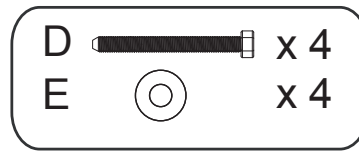

Fig. 6a

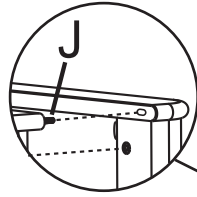

Fig. 6b

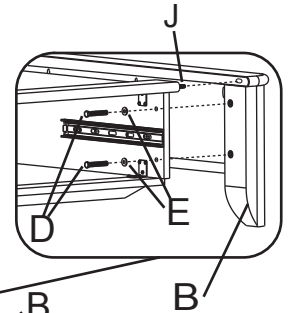
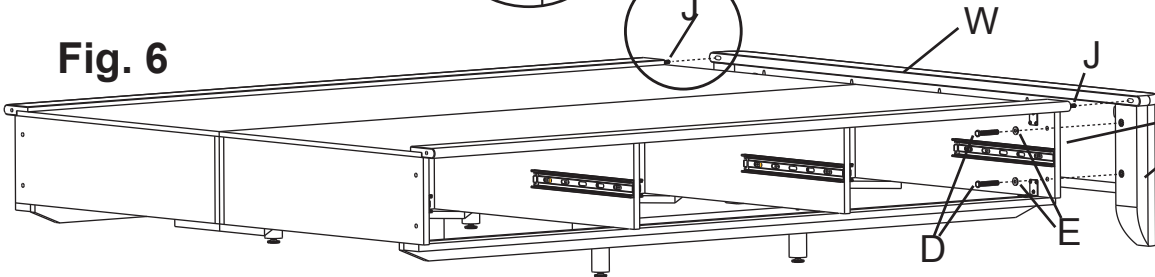

Fig. 6



6. Position the Footboard (B) against the end of the pedestal assembly and insert the dowels into the oval holes in the Top Cap (W). Place four Washers (E) over four 5/16" x 2¼" Hex Bolts (D) and thread the washer/bolts through the pre-drilled holes in the Pedestal Assembly and into the Footboard. Tighten the bolts with a 1/2" wrench. See Figures 6, 6a and 6b.

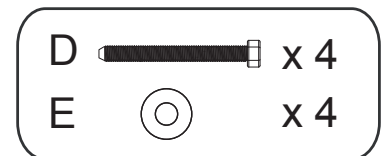
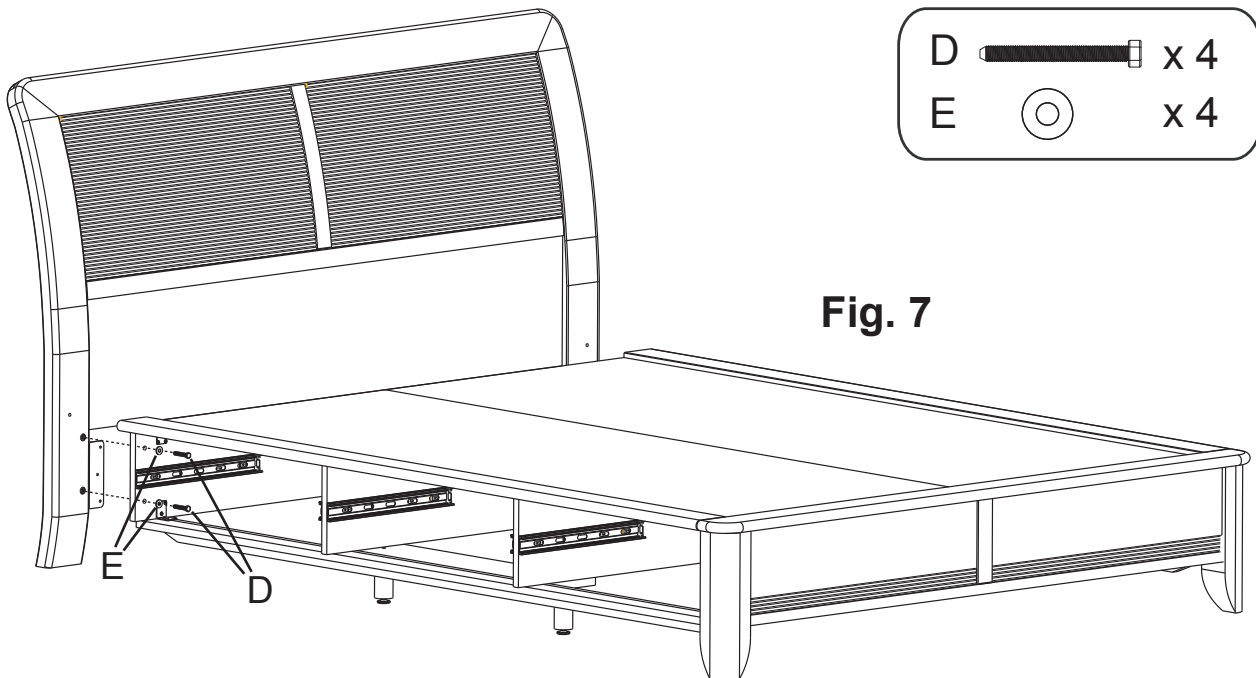
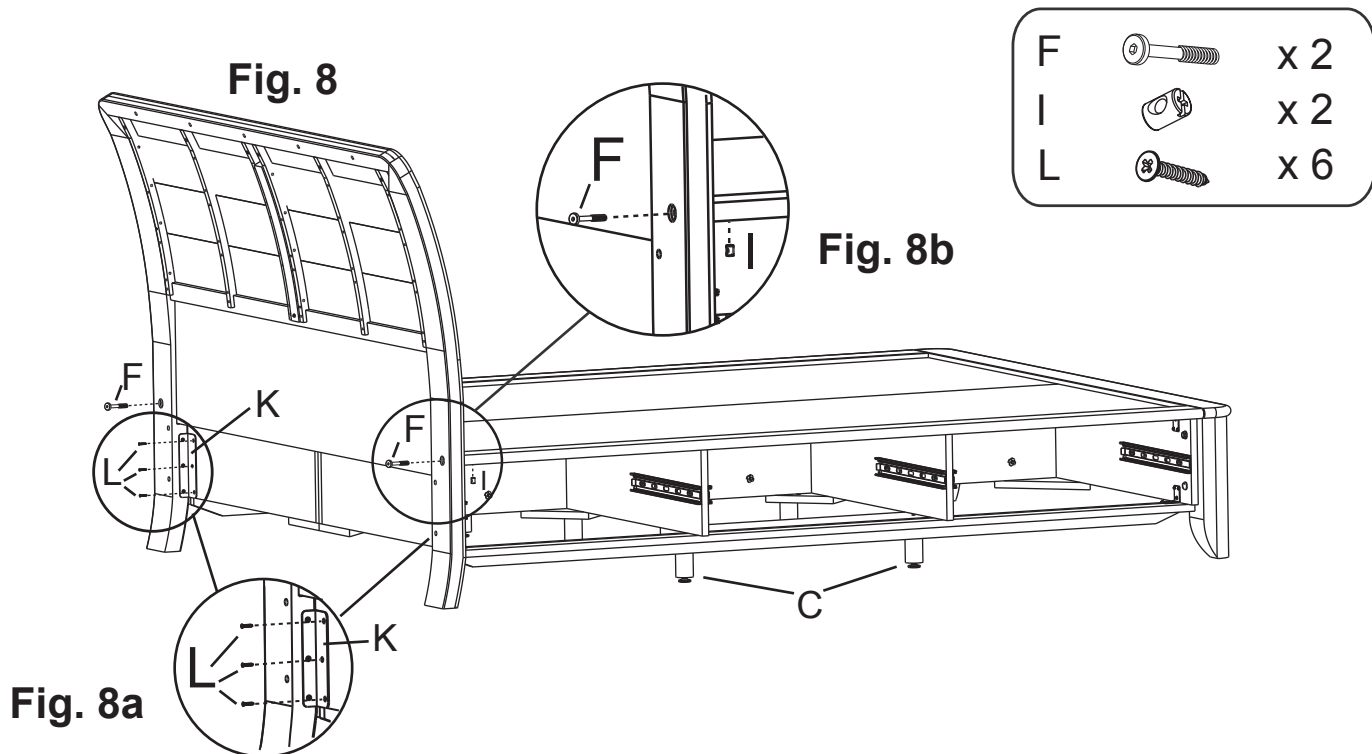

Fig. 7



7. Position the Headboard (A) against the end of the pedestal assembly. Place four Washers (E) over four 5/16" x 2¼" Hex Bolts (D) and thread the washer/bolts through the pre-drilled holes in the Pedestal Assembly and into the Headboard. Tighten the bolts with a 1/2" wrench. See Figure 7.



- Secure the preattached Angle Brackets (K) on the Headboard to the Pedestal Assembly with six #6 x 3/4" Flat Head Screws (L). See Figures 8 and 8a. Insert one Barrel Nut (I) into the predrilled hole on the bottom of the left pedestal rail. Using a slotted screwdriver, line up the hole in the Barrel Nut to the hole in the Headboard. Insert one 1/4" x 80mm Hex Bolt (F) into the predrilled hole in the Headboard and tighten with the provided Hex Wrench (S). Repeat for the right side. See Figures 8 and 8b.

If needed, adjust the six Foot Assemblies (C).

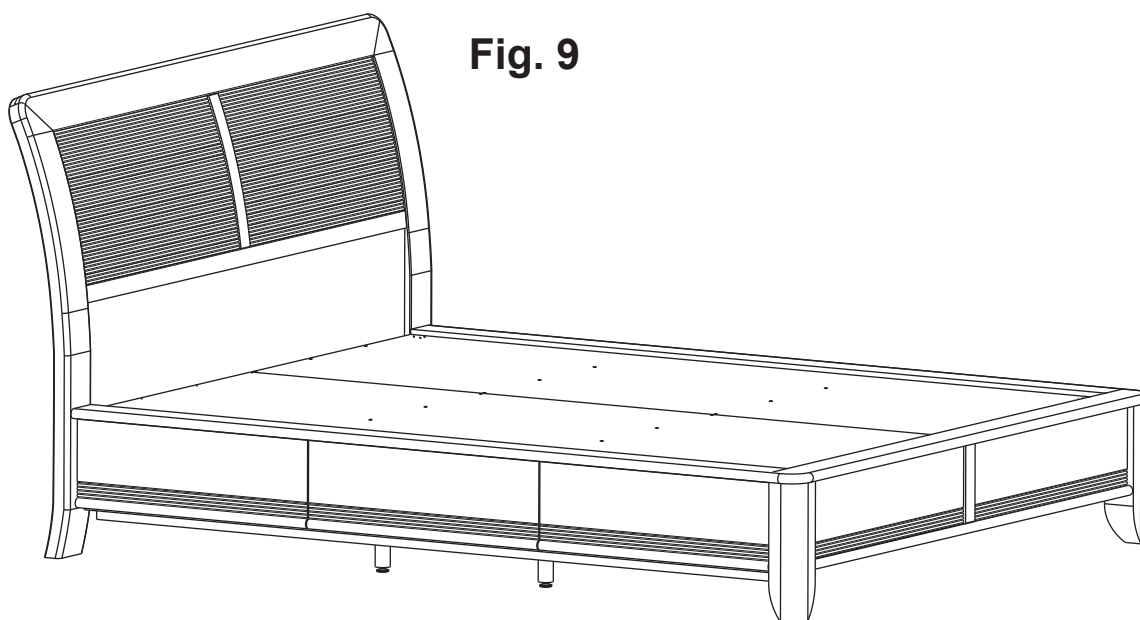

- Reinsert the six drawers, sleep well and enjoy!