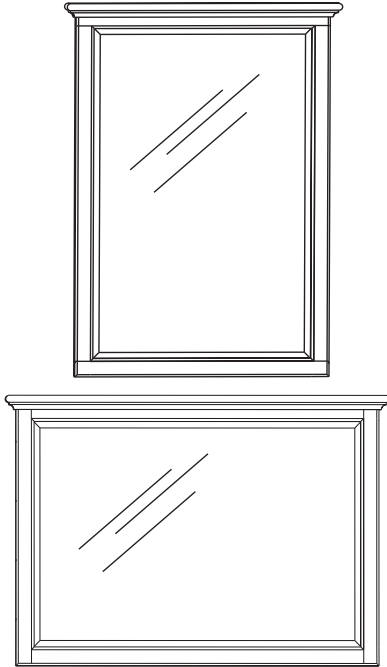


# Beveled Mirror

## 1500AUF; 1500AFGAC; 1500AFCAF

**AUF = Assembled Unfinished; AFGAC = Glazed Antique Cherry finish; AFCAF = Caffè finish**

Assembly Instructions



### Congratulations!

*This fine piece of furniture will make a gorgeous addition to your home. For the best results, read the Finishing Hints (if you purchased the AUF version) and/or the Assembly Instructions before you begin your project.*

### IMPORTANT NOTES:

- For normal household use only. **Not** recommended for commercial use.
- Handle the mirror with care. Glass is fragile.
- Before you begin your project, completely read the Finishing Hints and/or Assembly Instructions.
- Store this item: 1- in its box; 2- in a dry place; 3- in temperatures that range from 40°F to 90°F (not on a cold and possibly damp cement floor).
- Periodically inspect your furniture for any loose glue joints, screws or any other problem that might affect the stability of your furniture. Tighten or repair as needed.

**DESIGN SUBJECT TO CHANGE WITHOUT NOTICE.**



**CALL US FIRST!** *Do not return this item to the store.*

**Service Policy:** We will replace any part that is defective, missing or damaged during assembly. Please contact Whittier Wood Products customer service department directly by phone, fax, mail or email for a replacement part.

**Hours:** Our friendly customer service staff can be reached Monday-Friday 7:00 a.m. to 5:00 p.m. (Pacific Time). You may leave a message 24 hours a day, seven days a week.

**To Order:** Designate the finish, provide the furniture model number found at the top of the page, the part letter, production code, quantity needed, reason for replacement and your full name, address and telephone number.

*Parts ship from our Eugene, Oregon factory within one or two business days from the time we receive your request. Please allow five to ten business days for delivery.*

**800-653-3336** • Outside the U.S. or Canada: 541-687-0213 • Fax: 541-687-2060  
www.whittierwood.com • P.O. Box 2827 • Eugene, Oregon 97402, U.S.A.

**Whittier  
Wood**  
FURNITURE

P.O. Box 2827  
Eugene, OR 97402 USA

Production Code:

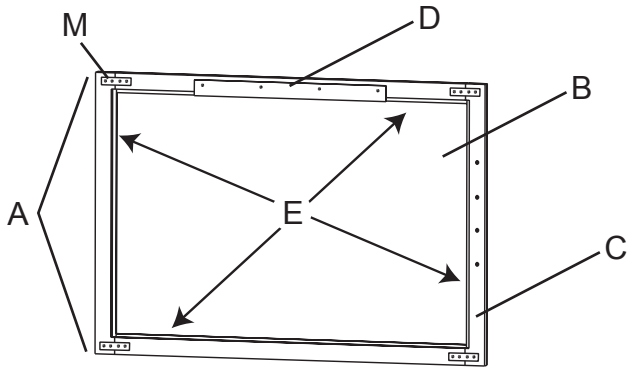
VN

06/10

# 1500AUF/AFGAC/AFCAF Beveled Mirror — Parts List

Please identify the parts and check that quantities received match what is on this list.

If you need to replace a part, refer to the following letter and item name.



A — Mirror Assembly — Qty. 1

B — Mirror — Qty. 1 (inserted)

C — Mirror Frame — Qty. 1 (attached)

D — Mirror Frame Bracket — Qty. 1 (attached)

L — #6 x 3/4" Flat Head Screw  
— Qty. 20 (inserted)

M — 3/4" x 3" Steel Brace  
— Qty. 4 (attached)



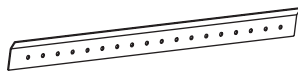
E — Glass Retainer— 11 ft.  
(inserted)



F — Short Top — Qty. 1



G — Long Top — Qty. 1



H — Mirror Wall Bracket — Qty. 1



I — #8x1-3/4" Pan Head Screw  
— Qty. 2



K — #8x1-1/4" Black Screw  
— Qty. 4

# 1500AUF/AFGAC/AFCAF Beveled Mirror Assembly Instructions

Tools Required: Phillips Head Screwdriver, Tape Measure

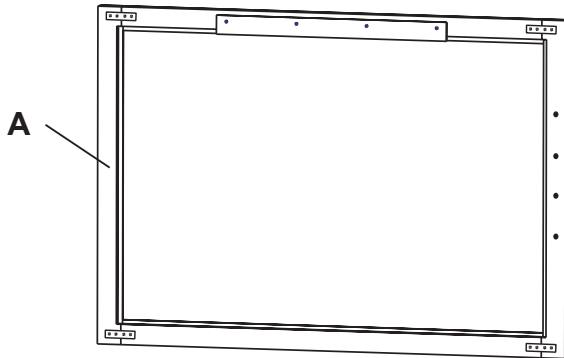


Fig. 1

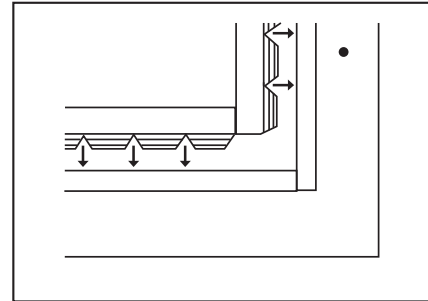


Fig. 1a

1. The Mirror Assembly (A) comes with the Mirror (B) in place for security during shipping. It is held in place by pieces of the Glass Retainer (E). If you need to remove the Glass Retainer (E) prior to applying finish to your Beveled Mirror (if you purchased the AUF version), place the Mirror Assembly (A) face-down on a clean protected surface and remove the Glass Retainer (E). Apply finish. After the finish is dry, replace the Glass Retainer pieces (E) as shown in Figure 1a. **CAUTION: DO NOT LEAN ON THE MIRROR WHEN YOU WORK ON THE FRAME.**

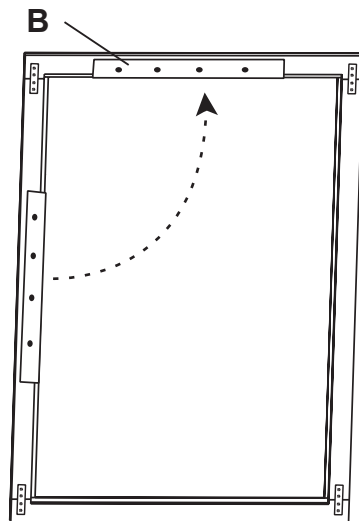
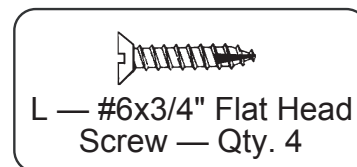
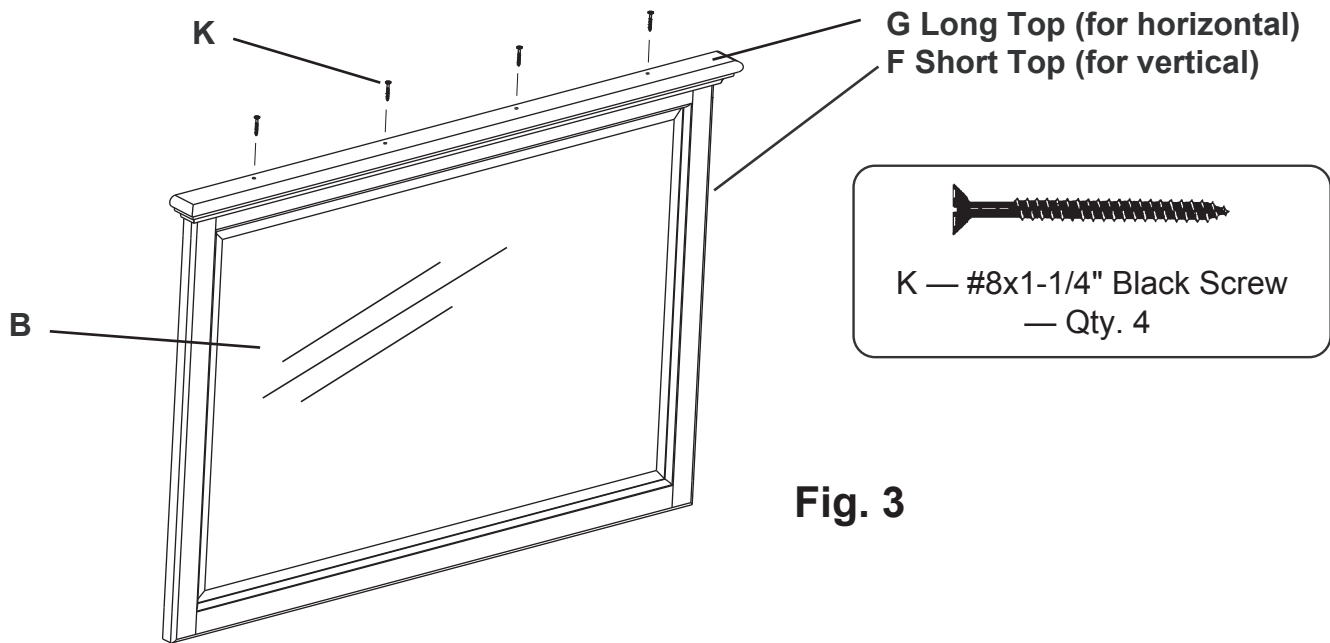


Fig. 2

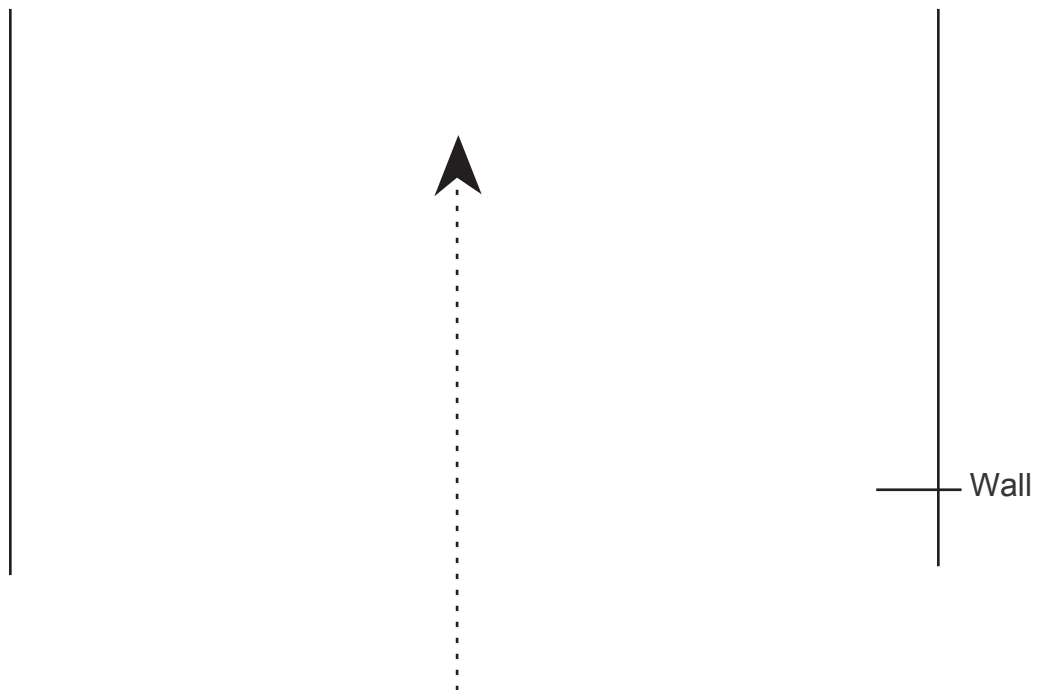


2. Decide if you want your Beveled Mirror to hang either vertically or horizontally. If you want it to hang vertically, remove the Mirror Frame Bracket (D) and line it up to the predrilled holes on the short side of the Mirror Frame (B) as in Figure 2. Attach with four #6x5/8" Undercut Screws.

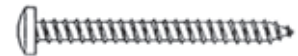


**Fig. 3**

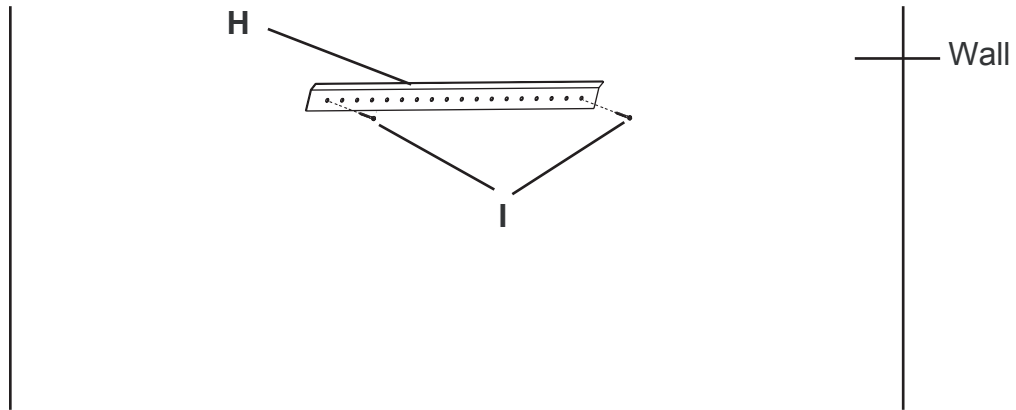
3. If you wish to attach a top, attach the Short Top (F) or the Long Top (G) to the Mirror Frame (C) with four #8x1-1/4" Black Screws (K) as shown in Figure 3.



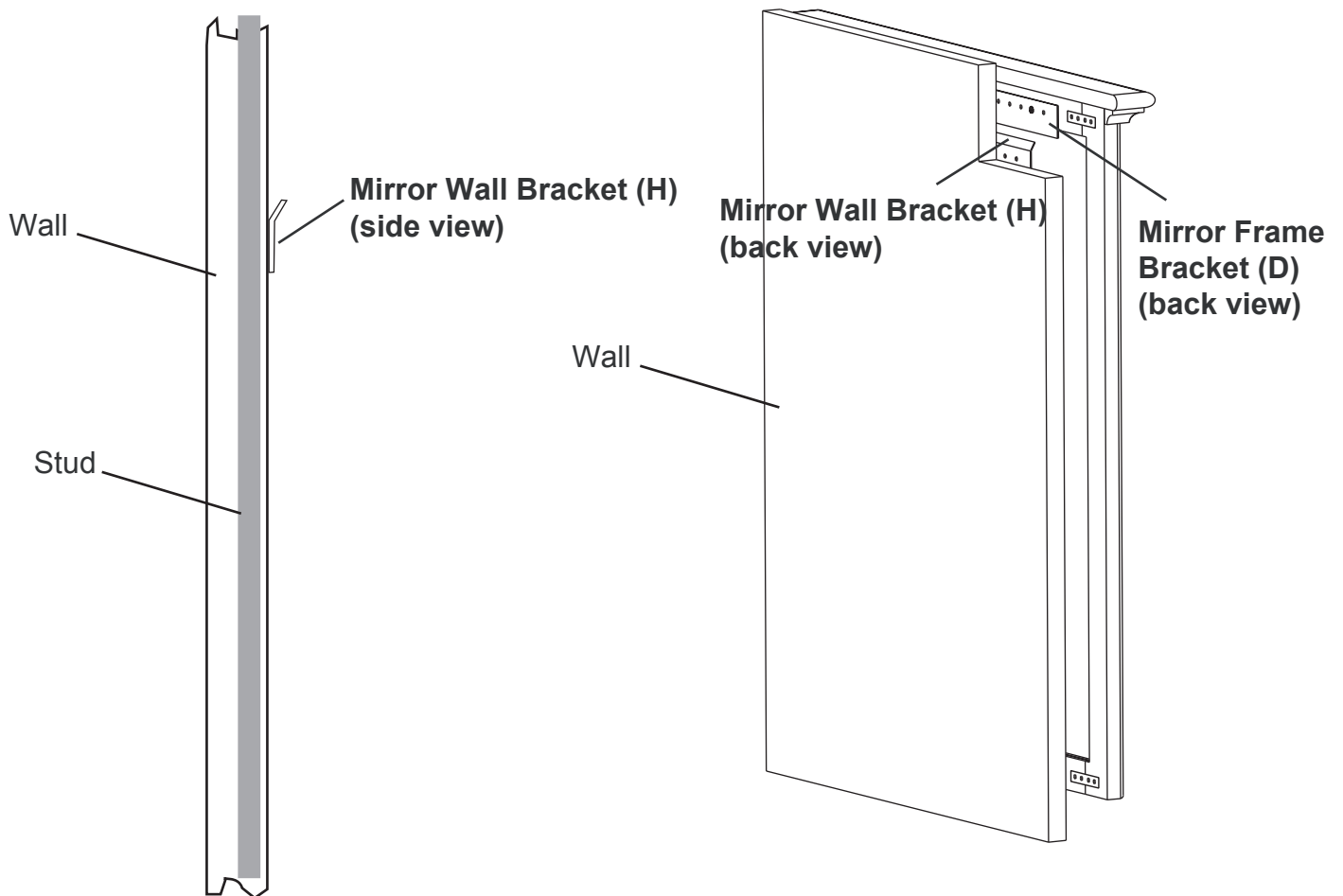
4. Determine where you want the bottom of your mirror to end and draw a faint pencil line on the wall. Using a tape measure, measure up 37-3/8" from that line (if your Beveled Mirror is vertical) or, if your Beveled Mirror is horizontal, measure up 25-3/8". Draw another faint line. The top line is where you attach the Mirror Wall Bracket (H). If you like, you can erase the faint bottom pencil mark.



I — #8x1-3/4" Pan  
Head Screw — Qty. 2



5. Locate two studs in the wall behind the space where you want to hang your Beveled Mirror. Affix the Mirror Wall Bracket (H) into the studs with two #8x1-3/4" Pan Head Screws. **If you cannot locate two studs**, purchase the proper wall attachment hardware for your type of wall and secure the bracket.



6. NOTE: The Mirror Wall Bracket (H) angles out at the top. When you hang your Beveled Mirror, the Mirror Frame Bracket (D) fits over the angled part of the Mirror Wall Bracket (H).

# Finishing Hints

## Choosing the Finish:

1. Choose a finish that will meet your expectations for the product you are finishing. Are you matching existing furniture or do you want a "natural" finish? Is the piece to be functional, decorative or both? The answers to these questions may affect the type of finish you choose.
2. Use products of the same brand to ensure compatibility of products.
3. **ALWAYS** follow the stain manufacturer's instructions. Alder is a porous hardwood and often looks best when following the finishing directions for softwoods
4. We recommend using a wood conditioner under oil base stains.
5. Work in a well ventilated and well lit area.

## Getting Started

1. **Assembly Instructions may contain special finishing information for that item.** Read both the Assembly Instructions and these Finishing Hints completely before beginning.
2. Sand the entire piece, using #220 grit sandpaper. Sand with the grain of the wood on flat surfaces and opposite the grain on turnings. Some parts are plywood. Be careful not to sand through the veneer. End grain (table top ends, seat edges, grooves on turnings, etc.) accepts more stain. Extra sanding in these areas with a #320 grit sandpaper will reduce stain absorption, creating a more evenly stained piece.
3. When sanding is completed, wipe the surface of your furniture with a cloth or tack rag. Make sure the item is free of dust before proceeding.

## Staining

1. Read and follow label directions. Stir stain well before starting.
2. Test stain on an inconspicuous spot on your project, or use the sample chip if one is provided. The sample chip must be sanded in the same way as your furniture kit to ensure the piece will accept the stain similarly. Put at least one coat of your top coat over the stain sample, as it also affects the look of the stain. **Test every type of wood that is in your kit.** Some of our products include more than one type of wood, which may react differently to the stain color. Sample chips for the different woods may be included. It may be necessary to add a second coat of stain to lighter woods to match the darker woods in your kit.

## Basic Equipment:

- |  |   |  |
|--|---|--|
| <input type="checkbox"/> Rubber gloves | <input type="checkbox"/> Tack cloth                       | <input type="checkbox"/> #220 & #320 sandpaper |
| <input type="checkbox"/> Rags          | <input type="checkbox"/> Drop cloth                       | <input type="checkbox"/> Mineral spirits       |
| <input type="checkbox"/> Paper towels  | <input type="checkbox"/> Paint brushes (bristle and foam) | <input type="checkbox"/> Masking Tape          |
| <input type="checkbox"/> Q-tips        |   |  |

3. Apply stain with a poly brush or lint-free cloth. Apply stain over a small area and wipe off excess. Working in small areas will make the color easier to control.
4. Q-tips are ideal for hard to reach areas.
5. Allow to dry thoroughly before proceeding.

## Applying the Top Coat:

**No top coat is required if using paint.**

1. **Always read and follow all label directions.** Stir your finish coat gently, **do not shake.** It will create bubbles that are hard to remove.
2. **All surfaces** (including the underside of table tops and inside drawers) **must be sealed with at least one layer of a top coat.** This will help minimize wood swelling, shrinkage, warping and cupping due to changes in moisture content or temperature.
3. We recommend that you **apply a minimum of two coats when using polyurethane or varnish (especially on all table top and work surfaces).** Sand lightly between coats using a #320 grit sandpaper or 00 steel wool for the smoothest possible finish.
4. Some water-based finishes tend to raise the grain slightly. This can be easily controlled with this sanding step. However, do not use steel wool when using water-based finishes. Strands of steel fiber caught in the wood can cause rust spots when coated with any water-based product.

## Painting:

1. For best results when painting, first coat the wood with a primer. An oil based primer would be best for a smooth finish. If you do not wish to use a solvent based primer, a water based primer would work almost as well.
2. Buy a quality brand paint. You may use a satin, semi-gloss, or gloss sheen. Apply a second coat for a smooth finish. Lightly sand between coats using a #320 grit sandpaper, so that the second coat will bond well. Repeat as desired.
3. Since there is such a variation between paint manufacturers, refer to your paint supplier for specific advice on using the paint that you purchase.